

ARTICLE.

VERSION 1.0

Assembly Instructions

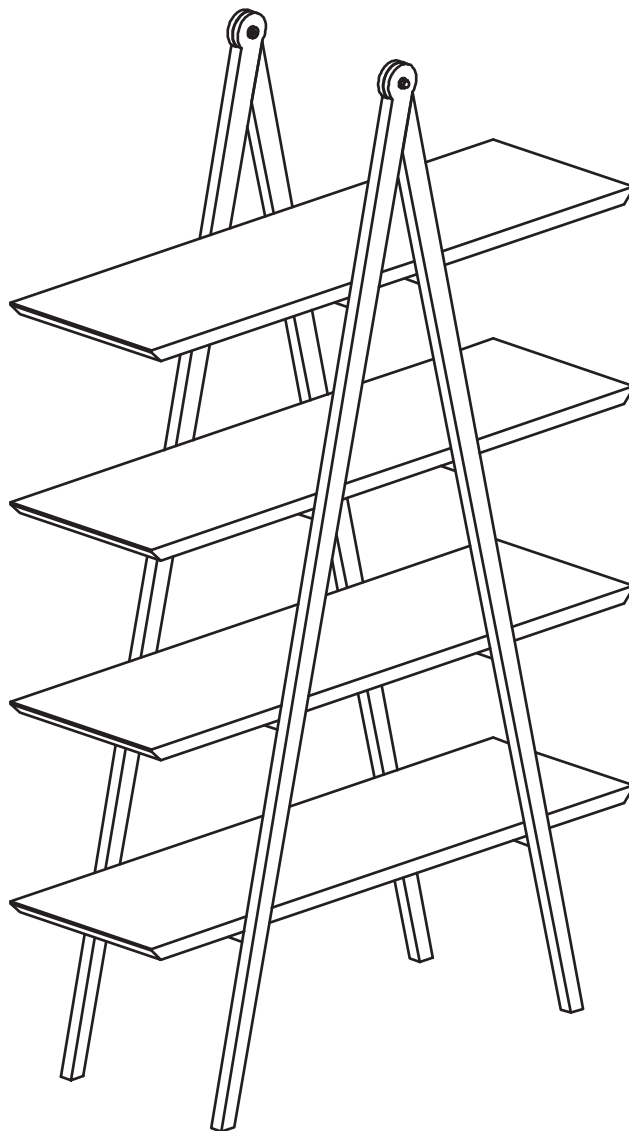

CALIPER

Shelf

ASSEMBLY INSTRUCTIONS

Read these instructions carefully and keep for future reference. Refer to parts inventory for guidance, and ensure you have all pieces before starting.

When assembling, place all parts on a soft, clean, and flat surface such as a carpet to prevent scratches.

If you're having difficulty, our friendly Customer Care team is always here to help. Call us at **1.888.746.3455** during business hours, email service@article.com or chat live at [article.com](https://www.article.com).

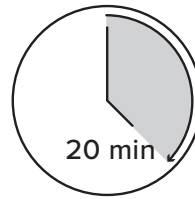

TIME



OF PEOPLE

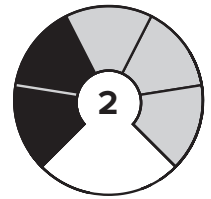









DIFFICULTY



ANTI-TIP

Installation Required

PARTS INVENTORY		
ID	DESCRIPTION	QTY
A	SHELF FRAME	2
B	TOP SHELF	1
C	SECOND SHELF	1
D	THIRD SHELF	1
E	BOTTOM SHELF	1

PARTS INVENTORY CONT.		
ID	DESCRIPTION	QTY
F	WRENCH 	1
G	ACORN NUT 	2
H	LARGE FLAT WASHER 	2
I	M8 × 40MM BOLT 	2
J	ALLEN KEY 	1
K	M6 WASHER 	16
L	M6 LOCK WASHER 	16
M	M6 × 50MM BOLT 	16

1

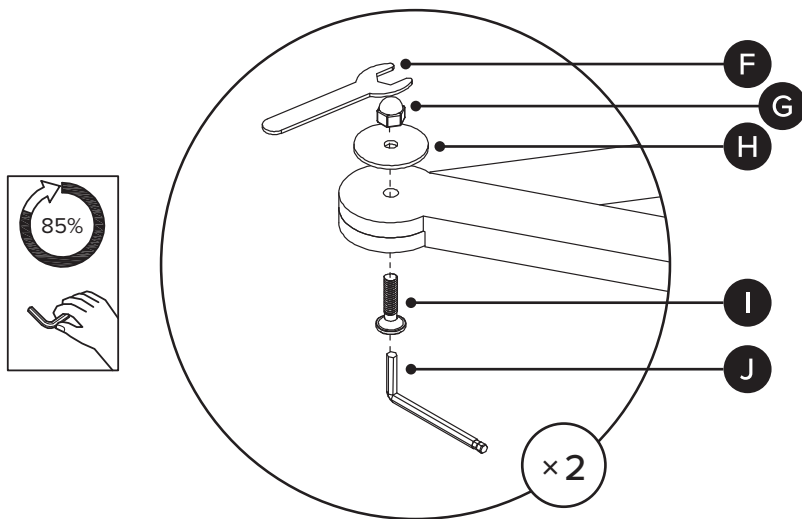
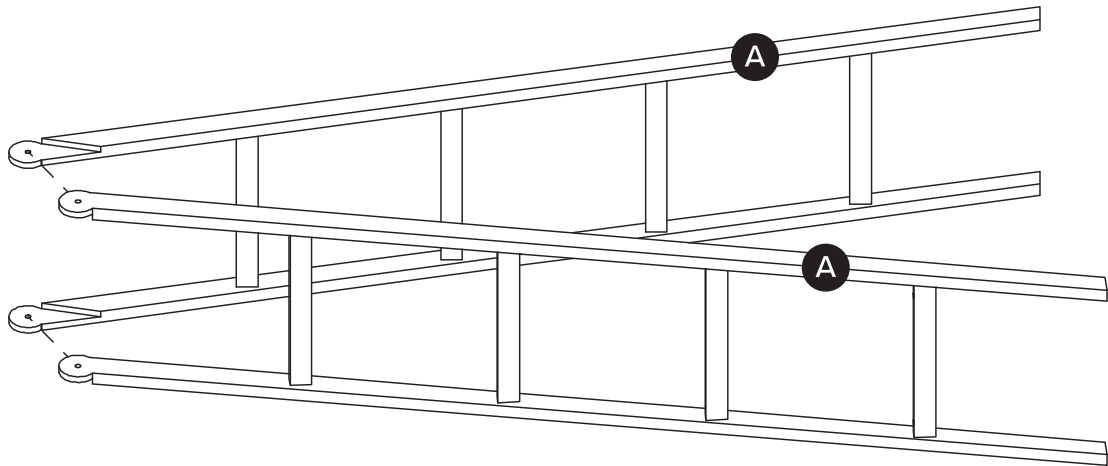

2A

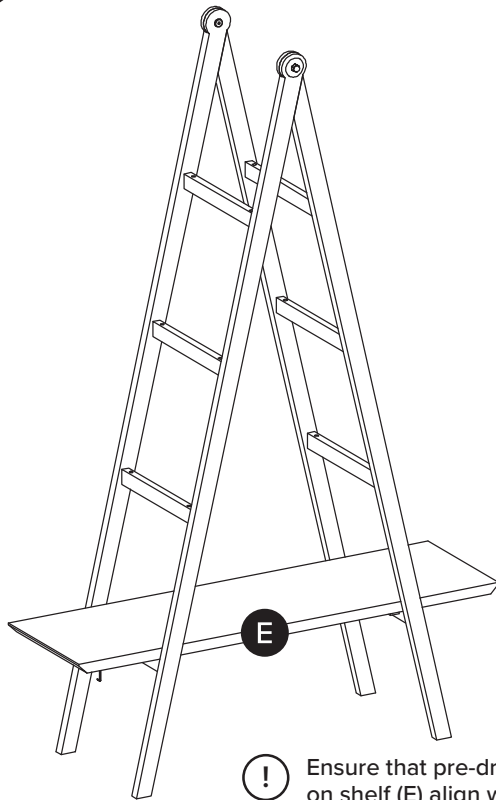

! Ensure that pre-drilled holes on shelf (E) align with frame.

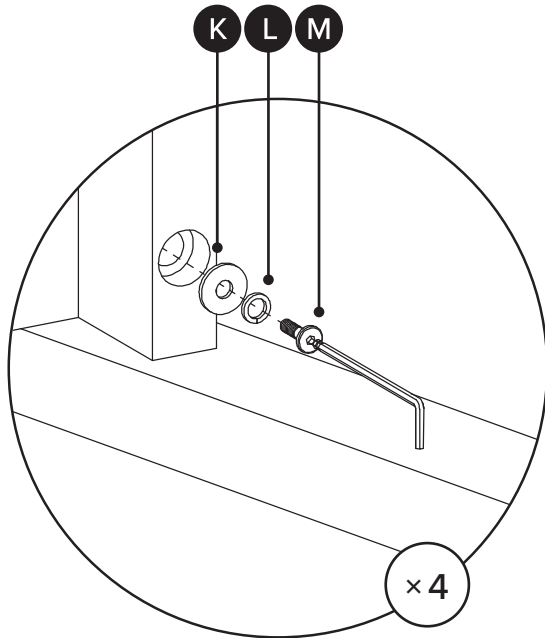

2B

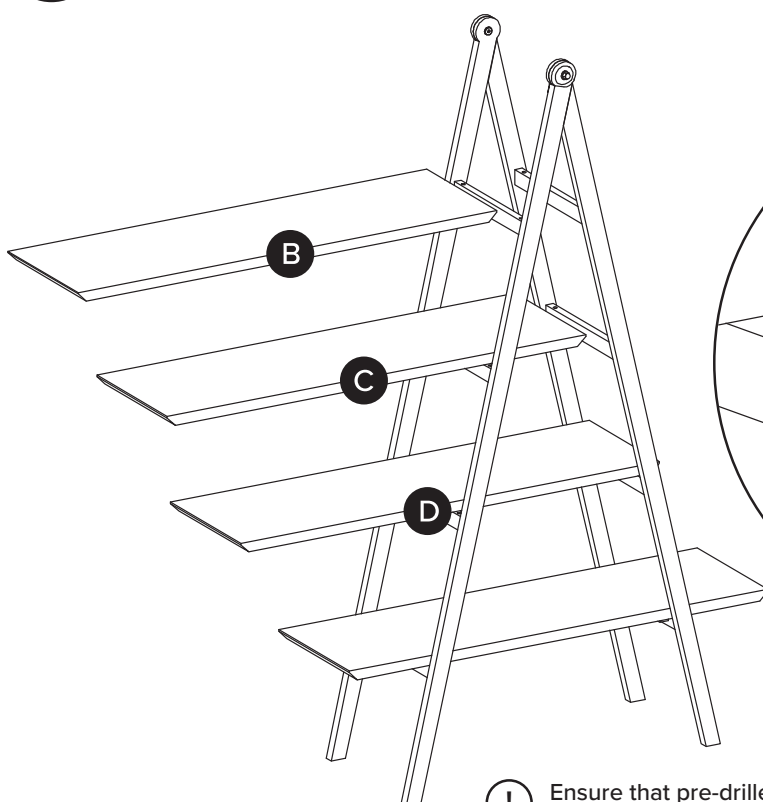

! Ensure that pre-drilled holes on each shelf align with frame.

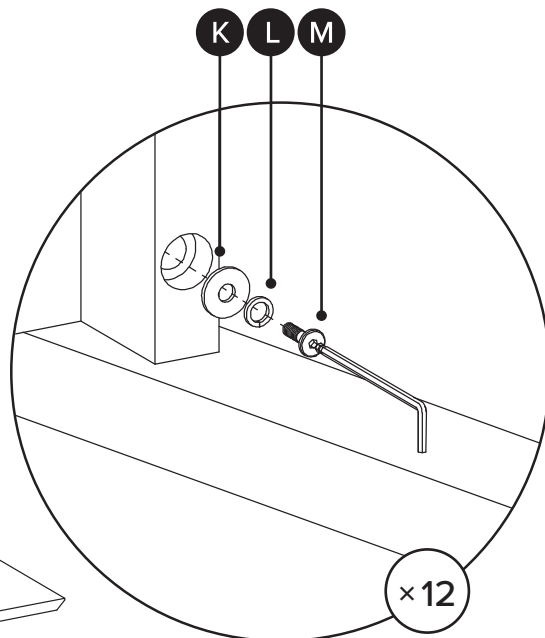

3

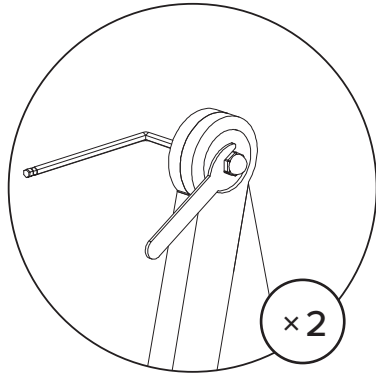

! Fully tighten all bolts.

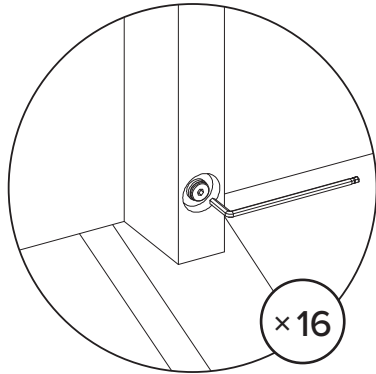

4

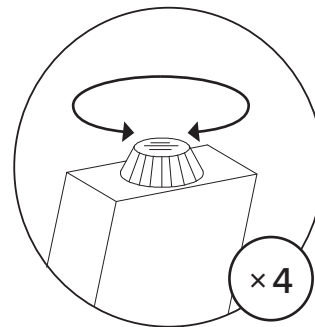
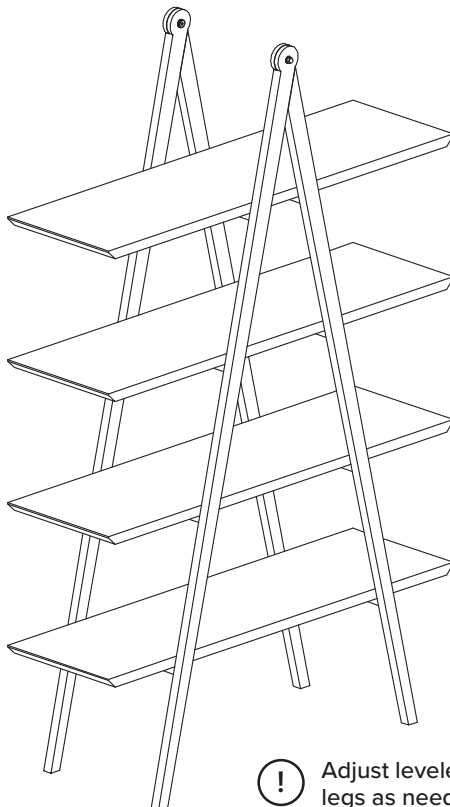

! Adjust levelers on legs as needed.



ANTI-TIP RESTRAINT INSTALLATION

WARNING!

Serious or fatal crushing injuries can occur from furniture tip-over. To help prevent tip-over:

- Install tip-over restraint provided.
- Do not set heavy objects on top of this product, unless the product is specifically designed to accommodate them.
- Never allow children to climb or hang on mirrors, shelves, consoles, or cabinets with doors and/or drawers.

Use of tip-over restraints may only reduce but not eliminate, the risk of tip-over.

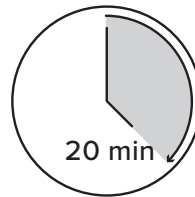

20 min

TIME

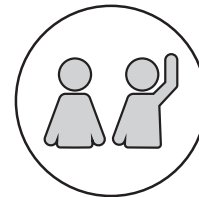

OF PEOPLE

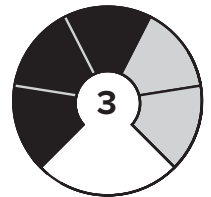



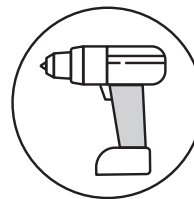

DIFFICULTY

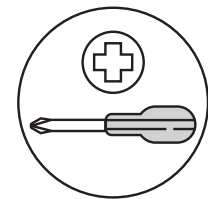

REQUIRED TOOL
8MM / 5/16" DRILL BIT



REQUIRED TOOL

PARTS INVENTORY		
ID	DESCRIPTION	QTY
A	BRACKET 	4
B	M4 × 20MM SCREW 	4
C	M8 × 51MM PLUG 	4
D	M6 × 70MM SCREW 	4
E	STRAP 	2



Hardware (C/D) to attach brackets to wall is designed for drywall. To attach this unit to another type of wall, consult with your local hardware store.

1

Attach pair of brackets to top shelf.

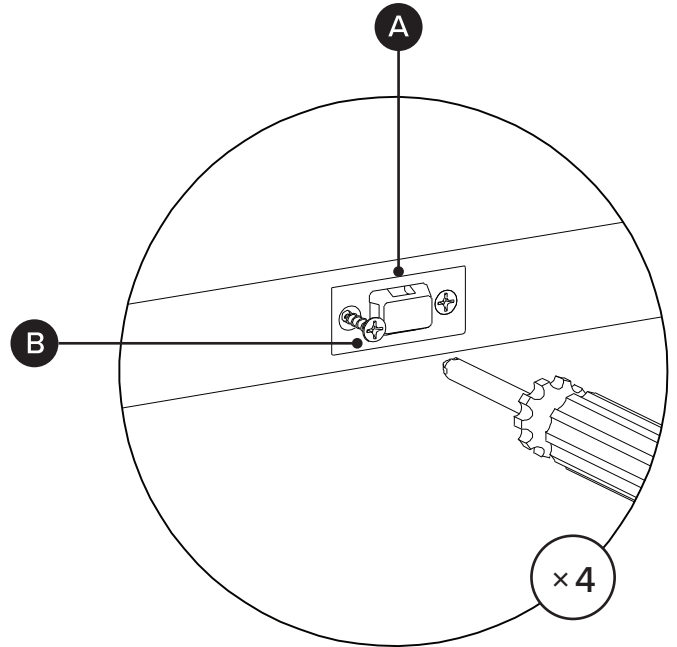
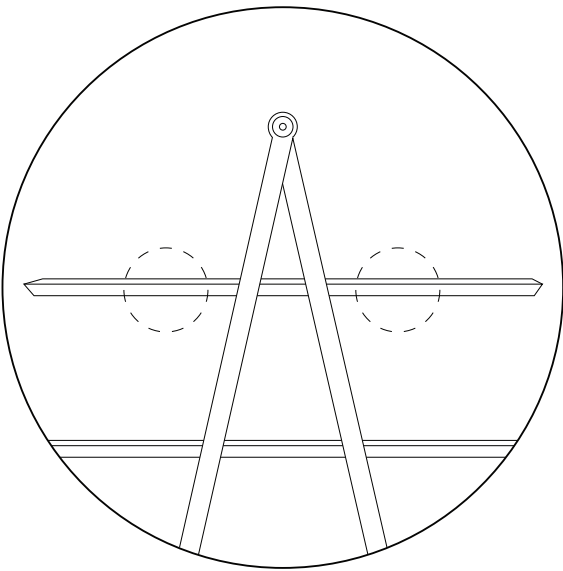

2

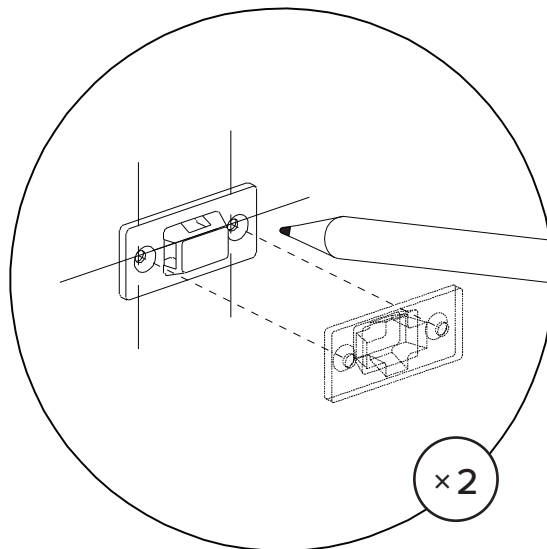

Mark on wall where second pair of brackets should be placed.

3

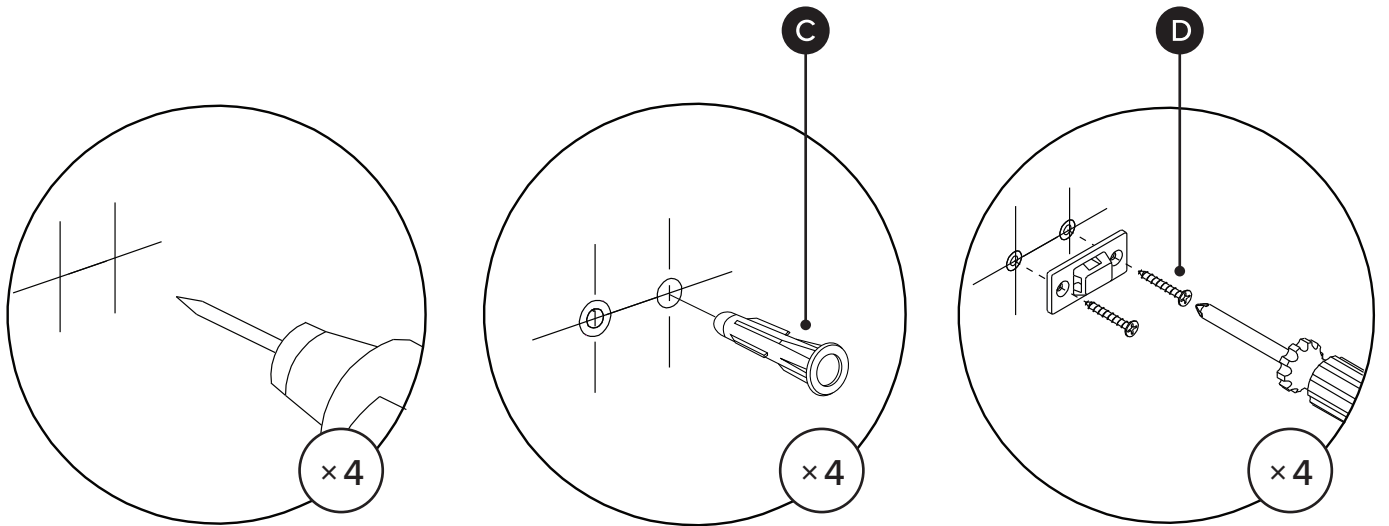

4

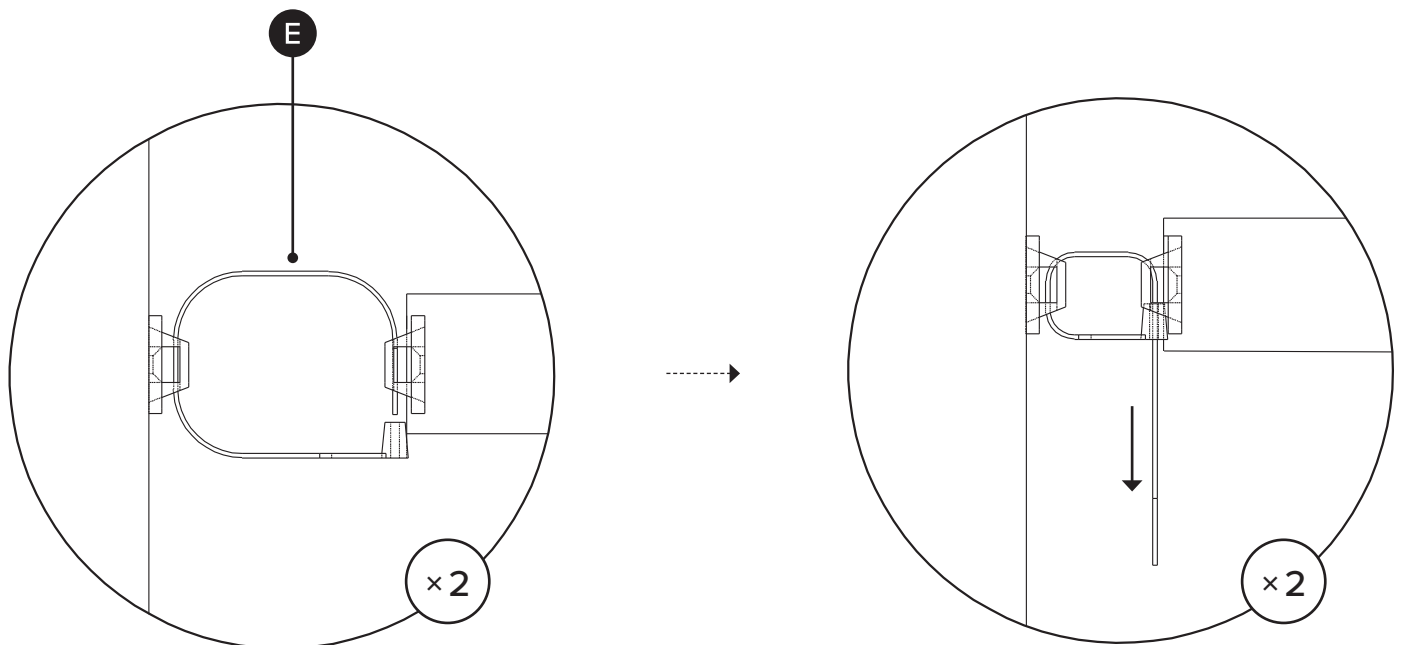

Align brackets on unit with brackets on wall.

Pull strap down until it snap-locks.