

ARTICLE.

VERSION 1.0

Assembly Instructions

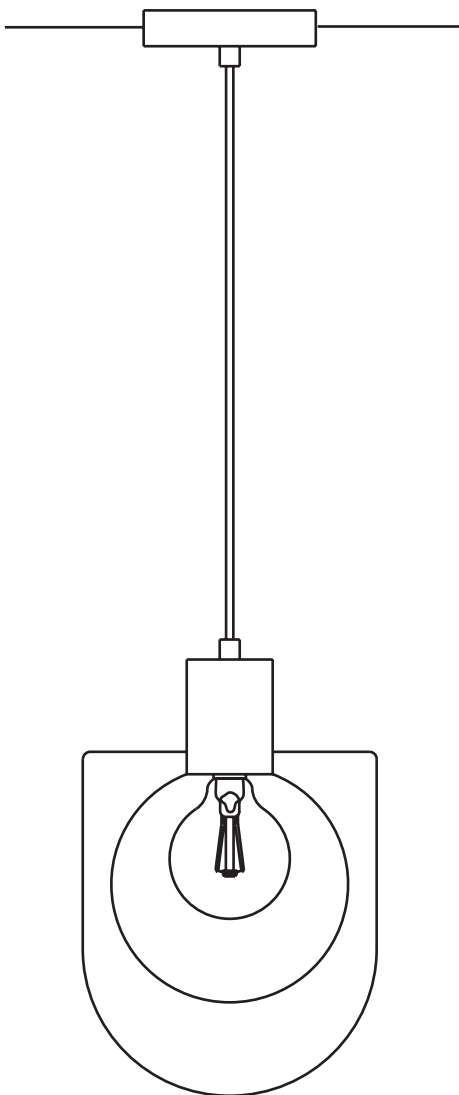

WYNDRO

Pendant Lamp

ASSEMBLY INSTRUCTIONS

Read these instructions carefully and keep for future reference. Refer to parts inventory for guidance, and ensure you have all pieces before starting.

When assembling, place all parts on a soft, clean, and flat surface such as a carpet to prevent scratches.

If you're having difficulty, our friendly Customer Care team is always here to help. Call us at **1.888.746.3455** during business hours, email service@article.com or chat live at [article.com](https://www.article.com).

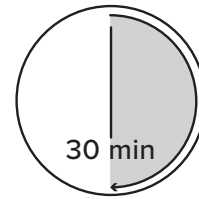

TIME



DIFFICULTY





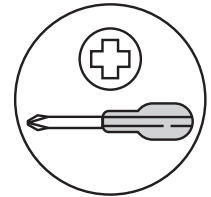

OF PEOPLE



REQUIRED TOOL

! Consultation with a professional electrician is recommended for the installation of this pendant lamp.

PARTS INVENTORY			
ID	DESCRIPTION		QTY
A	CROSSBAR BRACKET (PRE-INSTALLED)		1
B	LONG SCREW		2
C	WIRE NUT		3
D	SHORT GREEN SCREW (PRE-INSTALLED)		1
E	PENDANT LAMP WIRE		1
F	CANOPY PLATE (PRE-INSTALLED)		1
G	MEDIUM SCREW (PRE-INSTALLED)		2
H	SHADE		1
I	BULB (E26 3.5W LED G80)		1

! **CAUTION**
Turn off power at main circuit panel before starting installation.

1

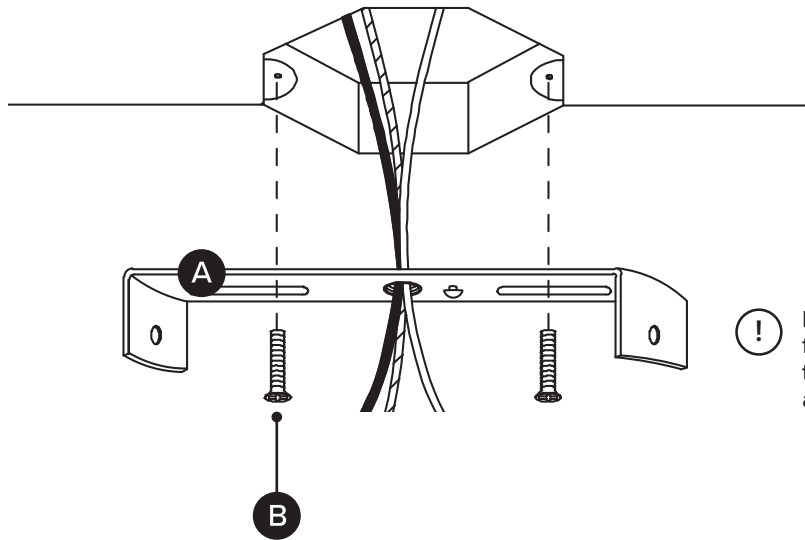

! Remove crossbar bracket (A) from canopy plate (F) and thread wires through before attaching to junction box.

2

! Match up wires by color and attach with wire nuts (C).
BLACK: Live
WHITE: Neutral
GREEN: Ground (shown as striped)

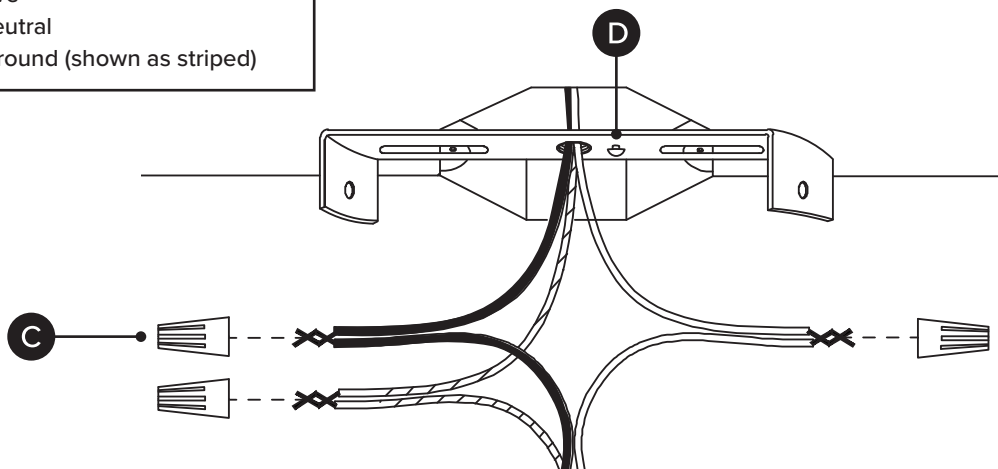

! If junction box does not have a green ground wire, attach ground wire from lamp to small green screw (D) on crossbar.

3

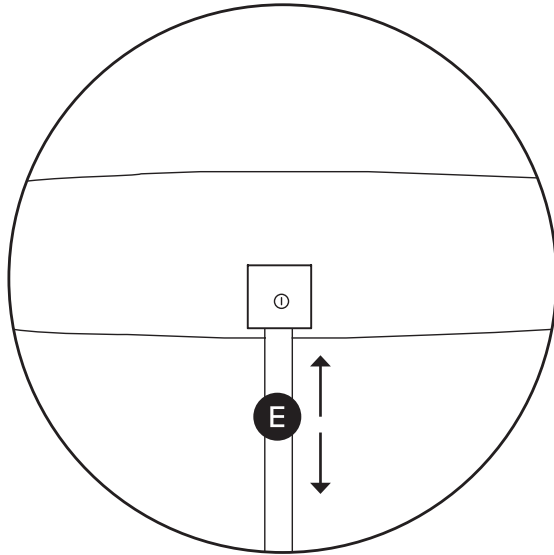

! Loosen screw on side of base to adjust length of wire (E) and tighten to secure.

4

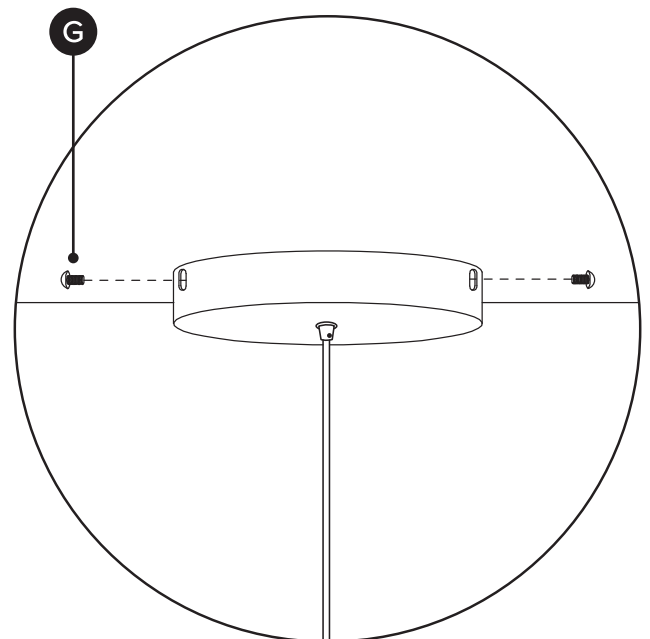
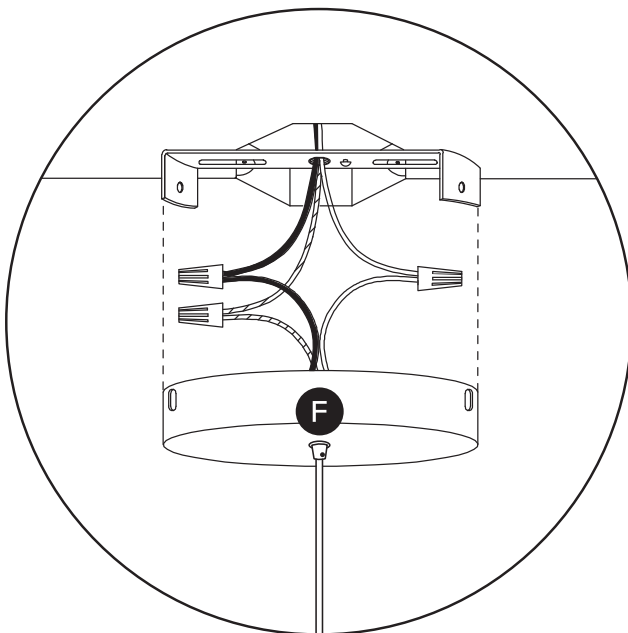

5

