

ARTICLE.

VERSION 1.0

Assembly Instructions

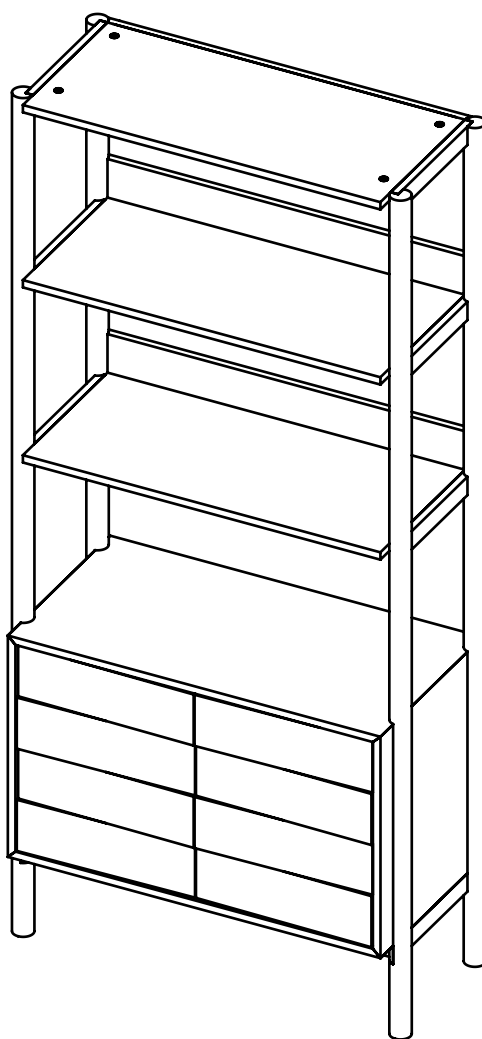

MERTO

Bookcase

ASSEMBLY INSTRUCTIONS

Read these instructions carefully and keep for future reference. Refer to parts inventory for guidance, and ensure you have all pieces before starting.

When assembling, place all parts on a soft, clean, and flat surface such as a carpet to prevent scratches.

If you're having difficulty, our friendly Customer Care team is always here to help. Call us at **1.888.746.3455** during business hours, email service@article.com or chat live at [article.com](https://www.article.com).

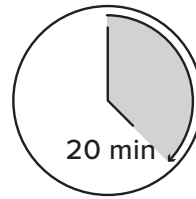

TIME



OF PEOPLE

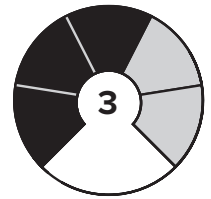

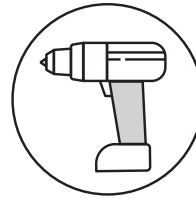

DIFFICULTY



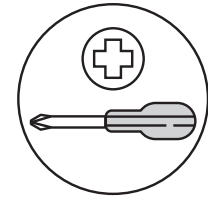



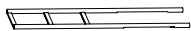

REQUIRED TOOL

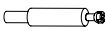

REQUIRED TOOL

PARTS INVENTORY		
ID	DESCRIPTION	QTY
A	CABINET	1
B	TOP PANEL	1
C	FIXED SHELF	2
D	CABINET SHELF	1
E	LEG 	2
F	WOODEN DOWEL 	12
G	CAMLOCK NUT 	12

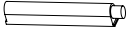
PARTS INVENTORY CONT.		
ID	DESCRIPTION	QTY
H	CAM LOCK SCREW 	12
I	SHELF PIN 	4
J	M6 x 30MM BOLT 	8
K	LOCK WASHER 	12
L	WASHER 	12
M	M6 x 15MM BOLT 	4
N	ALLEN KEY 	1
O	LATCH 	2

1

! Insert the latches (O) from the hardware bag.

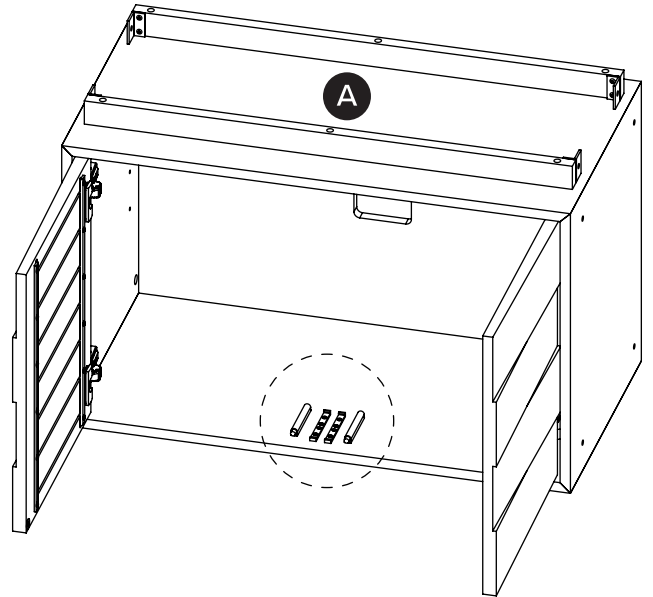
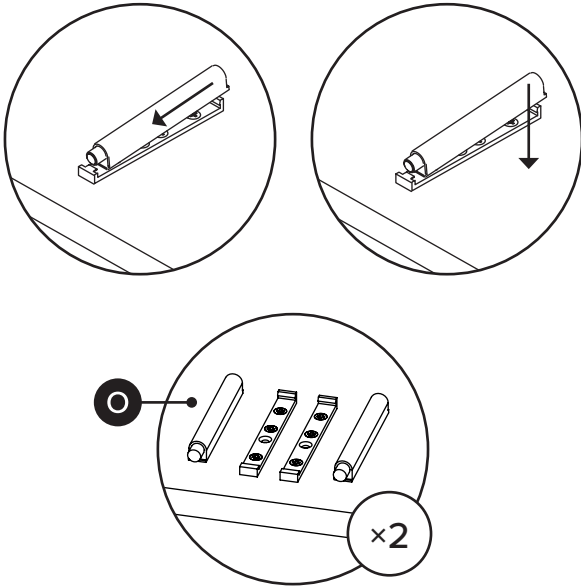

2

! Fixed shelf (C) assembly:

! Top panel (B) assembly:

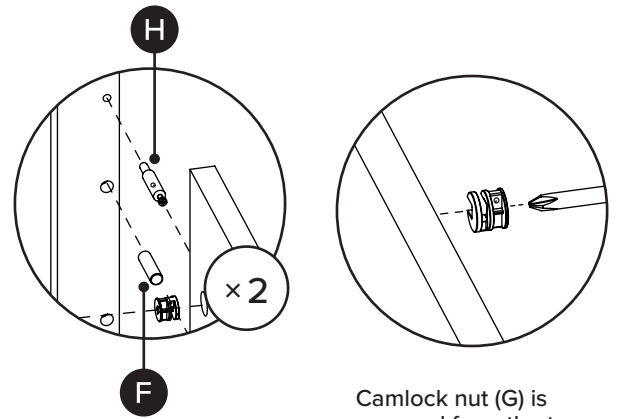
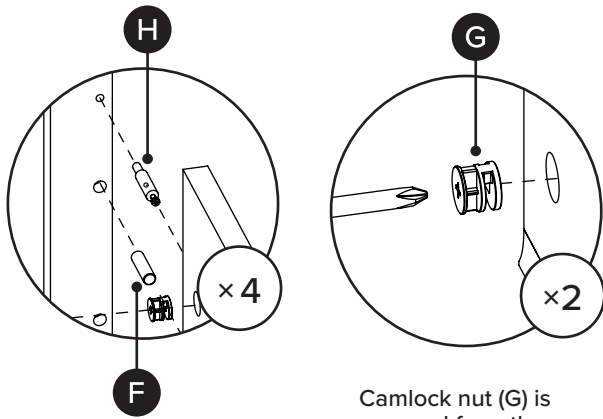

Camlock nut (G) is screwed from the

Camlock nut (G) is screwed from the top.

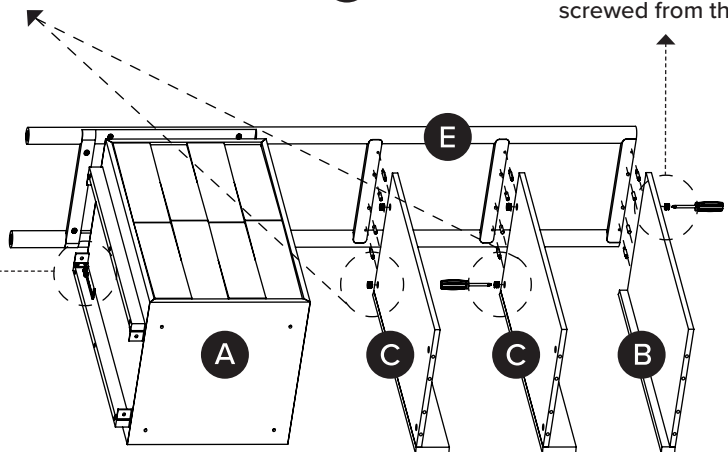
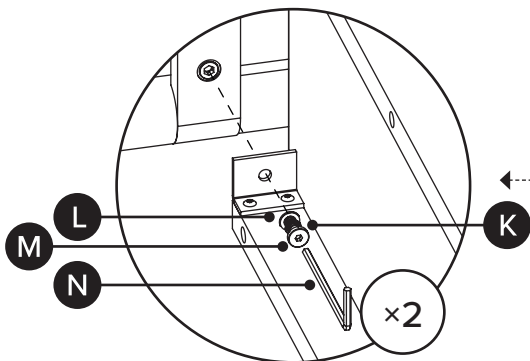

3

! Top panel (B) assembly:

! Fixed shelf (C) assembly:

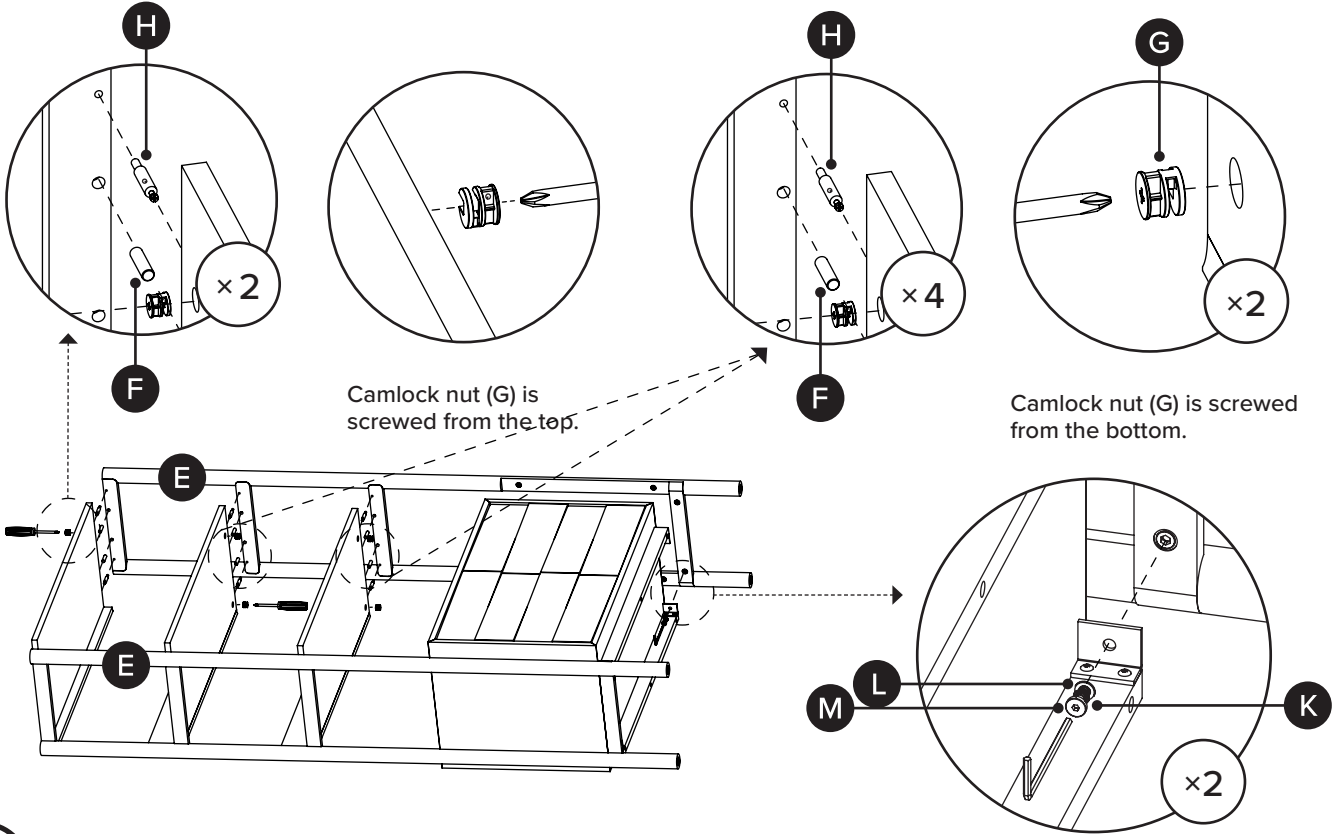

4

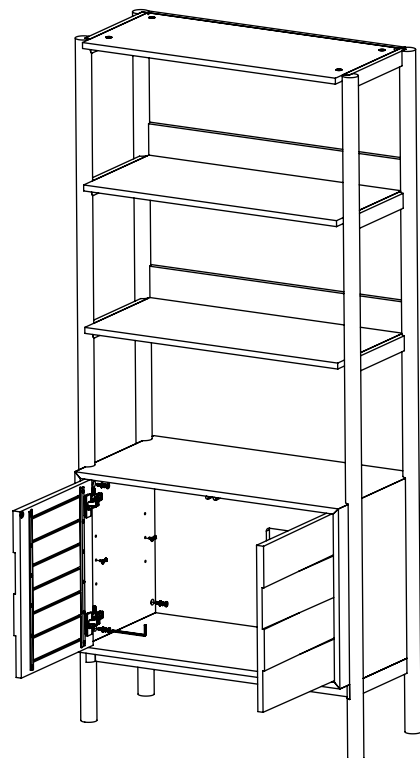
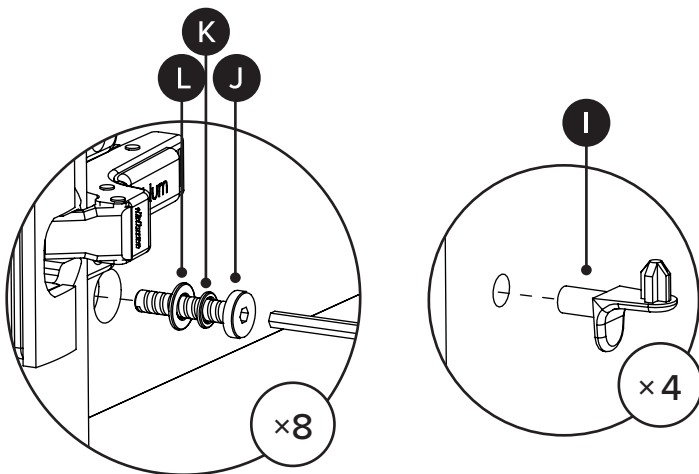

5

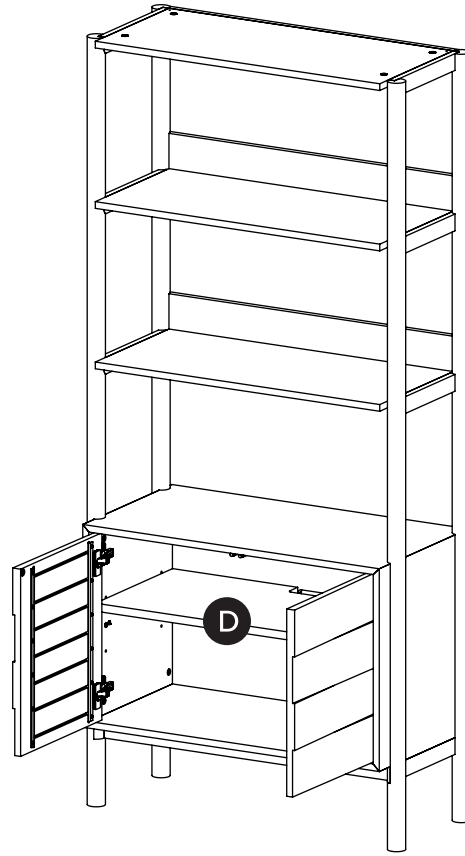
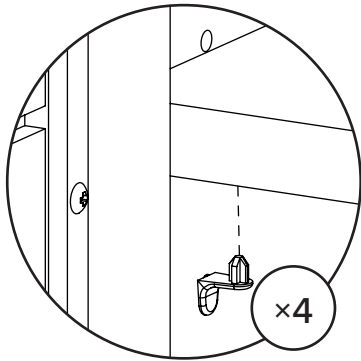

6

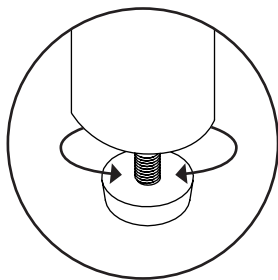

! Adjust levelers as needed.

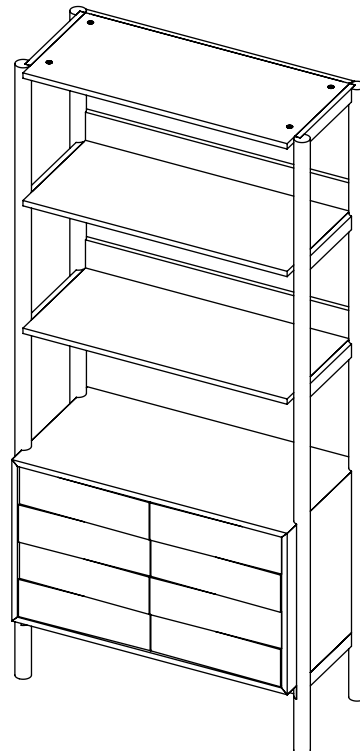

DOOR ADJUSTMENT INSTRUCTIONS

! During shipping, the doors of your cabinet may have shifted slightly. This can easily be corrected by tightening a few screws. Always start by adjusting the top hinge on the affected door.

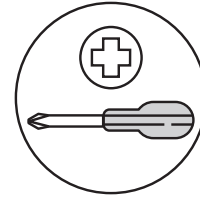

REQUIRED TOOL

7A

If the door needs adjustment forward or backward:

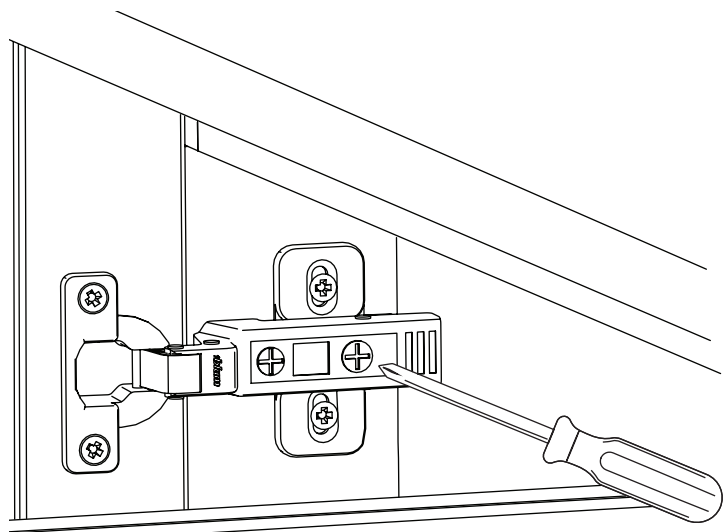
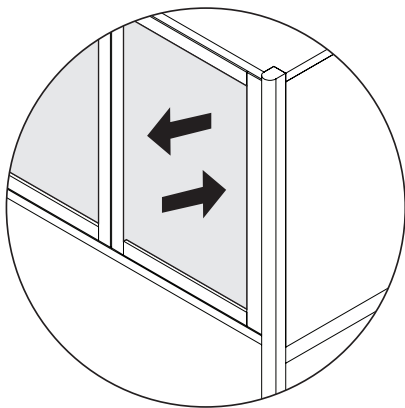

7B

If the door needs adjustment side to side:

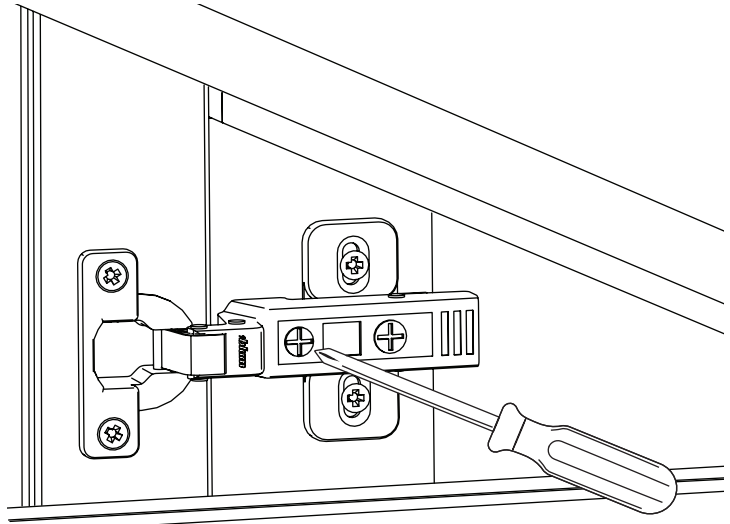
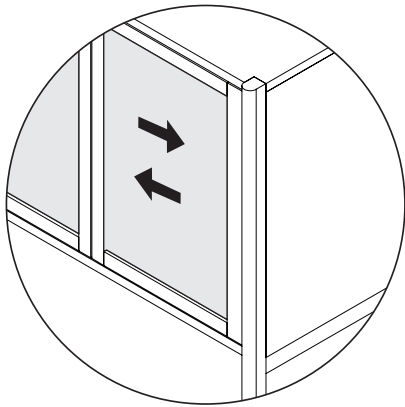

7C

If the door is crooked, adjust hinge(s) up or down:

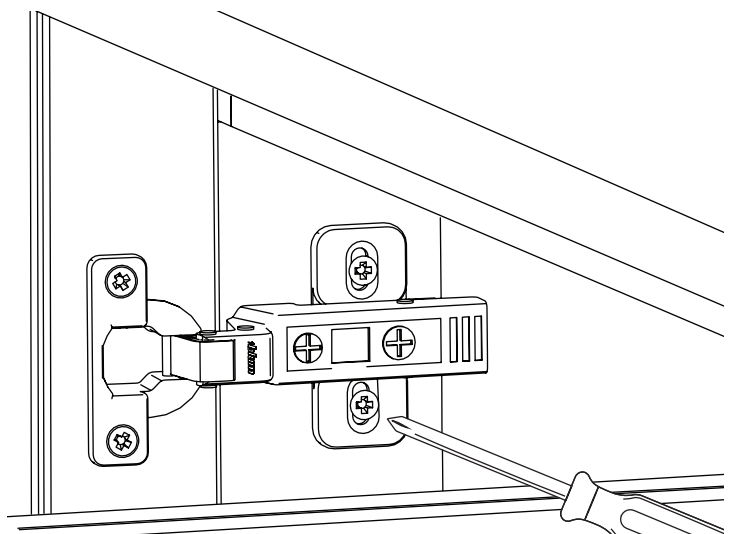
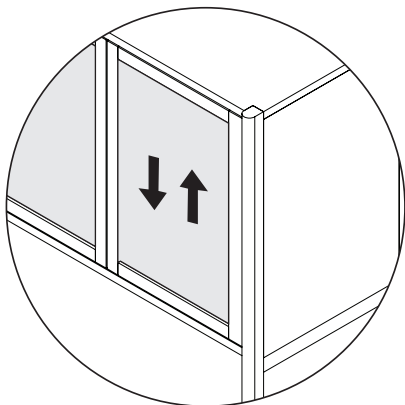



ANTI-TIP RESTRAINT INSTALLATION

WARNING!

Serious or fatal crushing injuries can occur from furniture tip-over. To help prevent tip-over:

- Install tip-over restraint provided.
- Do not set heavy objects on top of this product, unless the product is specifically designed to accommodate them.
- Never allow children to climb or hang on mirrors, shelves, consoles, or cabinets with doors and/or drawers.

Use of tip-over restraints may only reduce but not eliminate, the risk of tip-over.

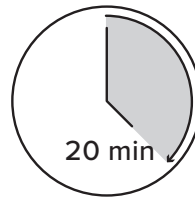

TIME

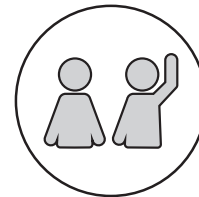

OF PEOPLE

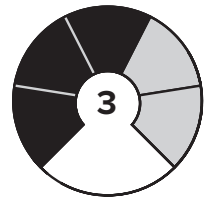



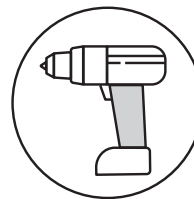

DIFFICULTY

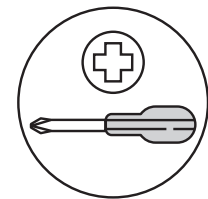

REQUIRED TOOL



REQUIRED TOOL

PARTS INVENTORY		
ID	DESCRIPTION	QTY
A	BRACKET 	2
B	M4 × 15MM SCREW 	2
C	M8 × 51MM PLUG 	2
D	M6 × 70MM SCREW 	2
E	WASHER 	2



Hardware (C/D) to attach brackets to wall is designed for drywall. To attach this unit to another type of wall, consult with your local hardware store.

1

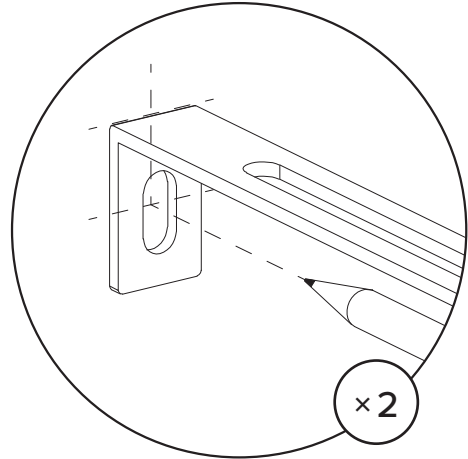
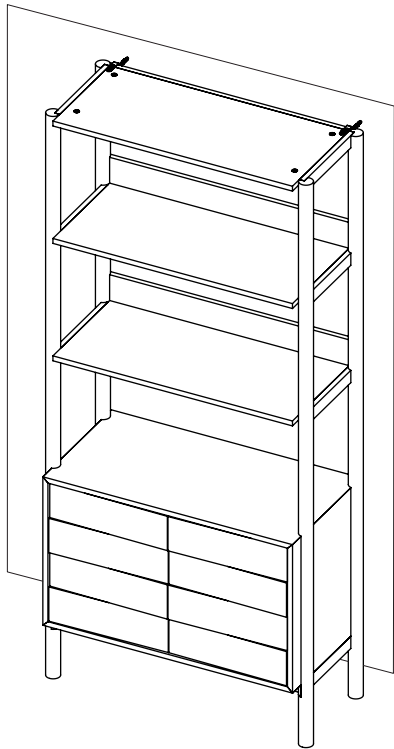

Place unit in desired location and mark on wall where holes should be drilled.

2

Drill holes into drywall, and attach unit to wall with appropriate hardware.

