

ARTICLE.

VERSION 1.1

Assembly Instructions

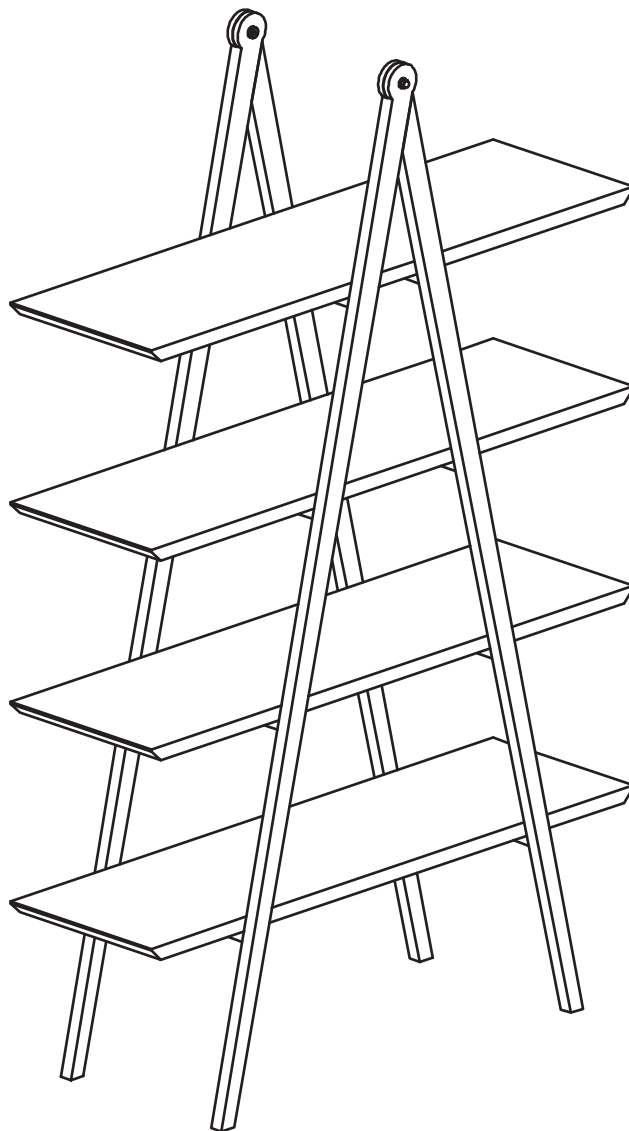

CALIPER

Shelf

ASSEMBLY INSTRUCTIONS

Read these instructions carefully and keep for future reference. Refer to parts inventory for guidance, and ensure you have all pieces before starting.

When assembling, place all parts on a soft, clean, and flat surface such as a carpet to prevent scratches.

If you're having difficulty, our friendly Customer Care team is always here to help. Call us at **1.888.746.3455** during business hours, email service@article.com or chat live at [article.com](https://www.article.com).

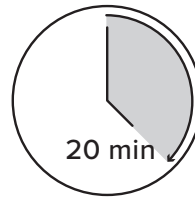

TIME





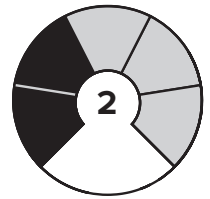





OF PEOPLE



DIFFICULTY

PARTS INVENTORY		
ID	DESCRIPTION	QTY
A	SHELF FRAME	2
B	TOP SHELF	1
C	SECOND SHELF	1
D	THIRD SHELF	1
E	BOTTOM SHELF	1

PARTS INVENTORY CONT.		
ID	DESCRIPTION	QTY
F	WRENCH 	1
G	ACORN NUT 	2
H	LARGE FLAT WASHER 	2
I	M8 × 40MM BOLT 	2
J	ALLEN KEY 	1
K	M6 WASHER 	16
L	M6 LOCK WASHER 	16
M	M6 × 50MM BOLT 	16

1

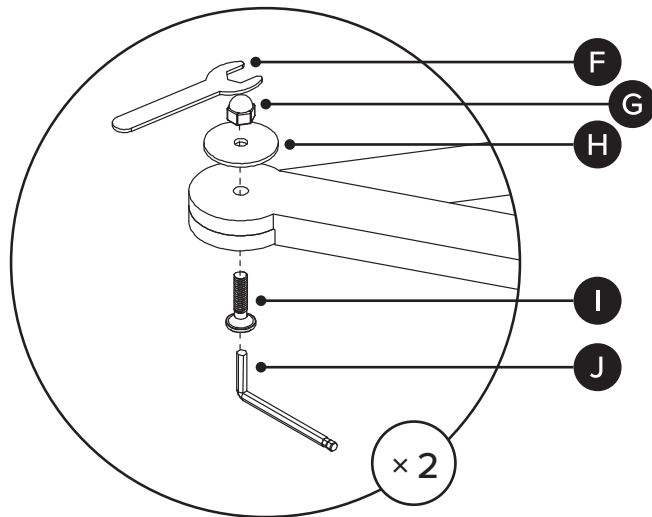
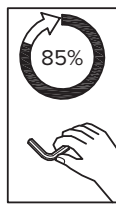
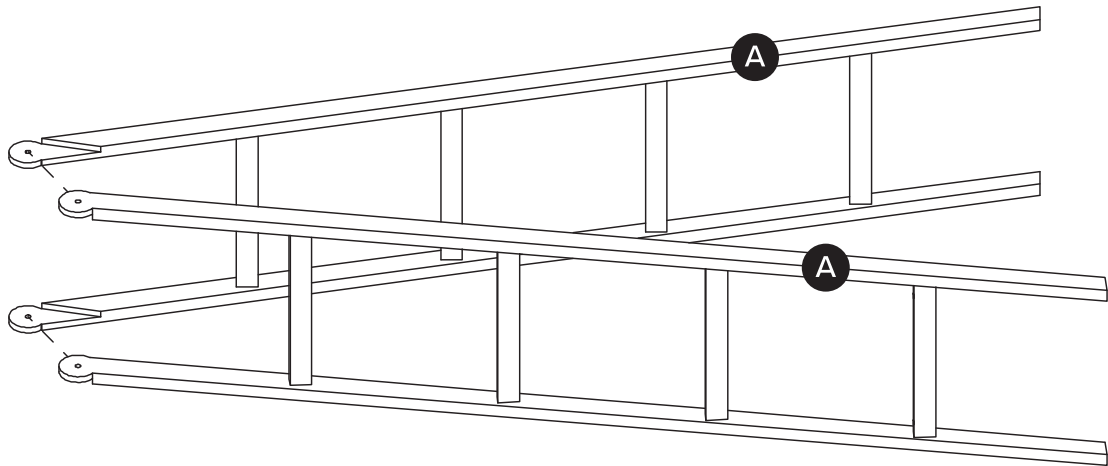

2A

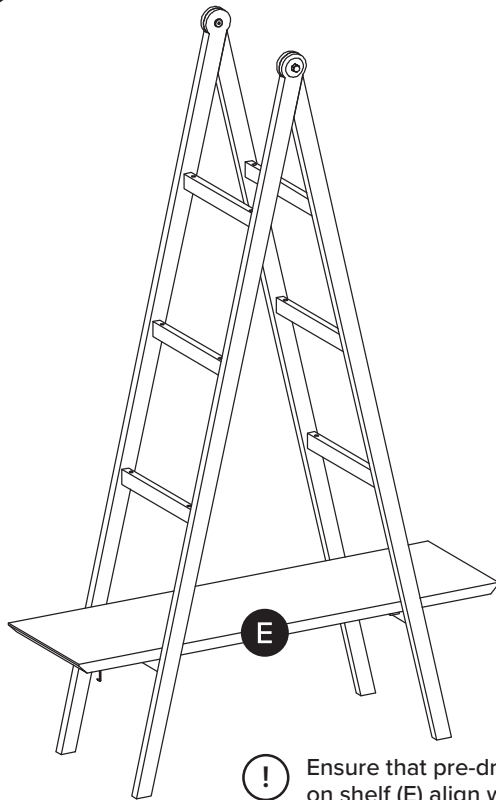

! Ensure that pre-drilled holes on shelf (E) align with frame.

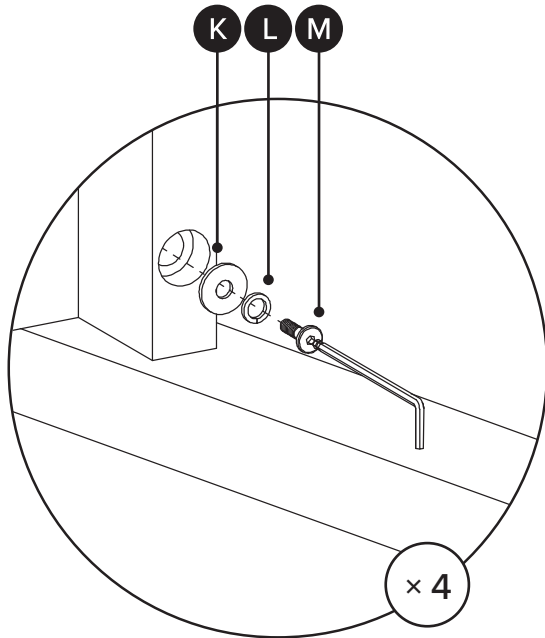

2B

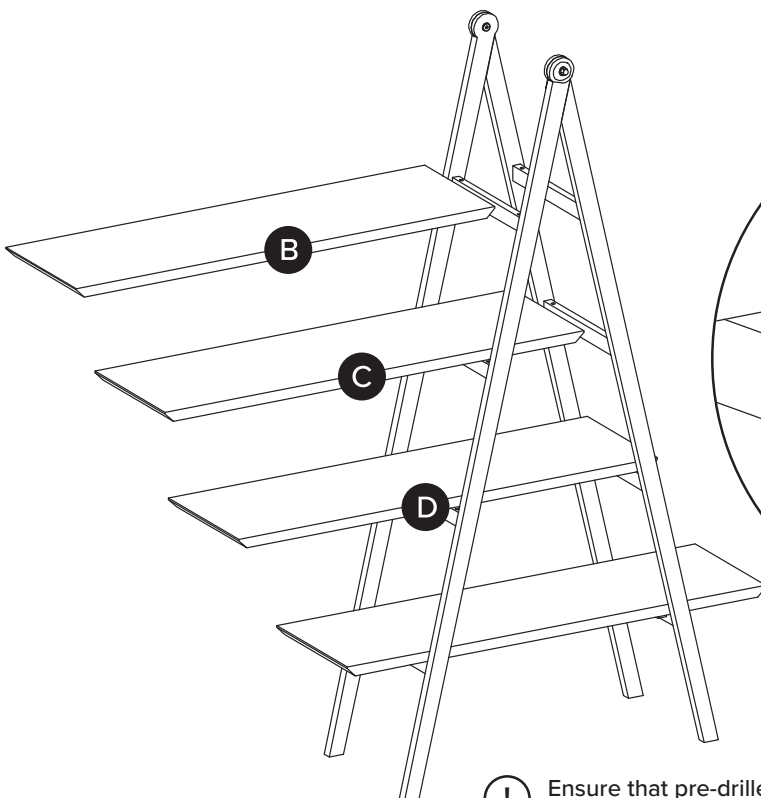

! Ensure that pre-drilled holes on each shelf align with frame.

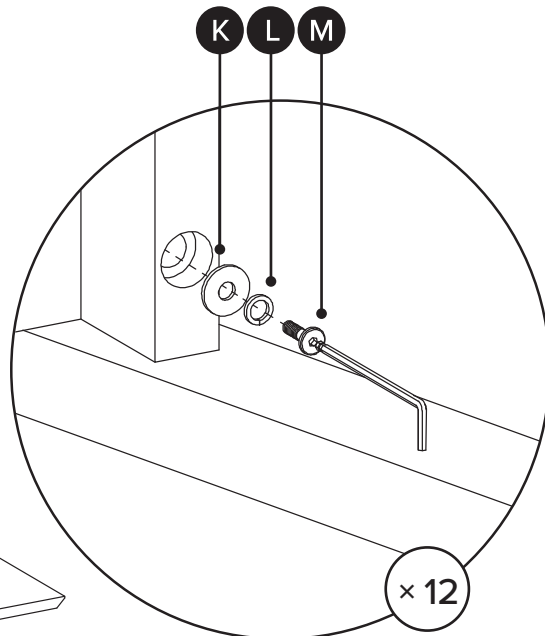

3

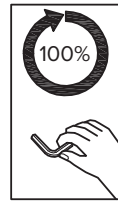
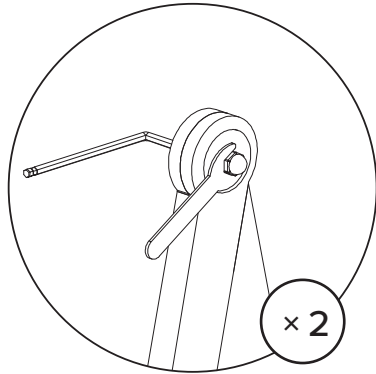

! Fully tighten all bolts.

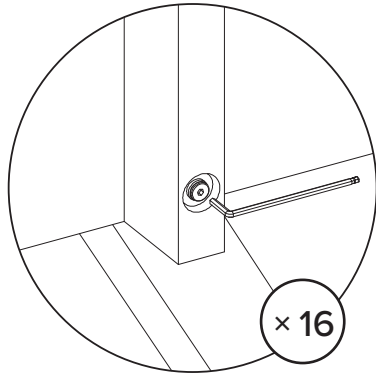

4

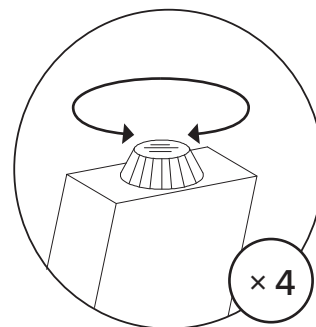
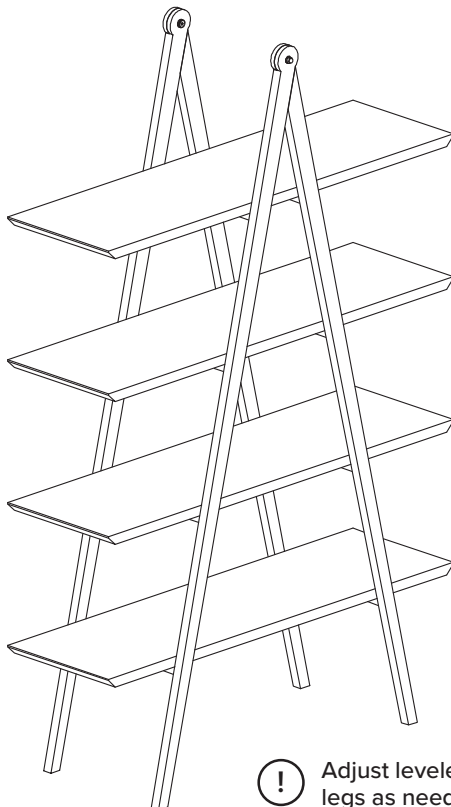

! Adjust levelers on legs as needed.