

ARTICLE.

VERSION 1.0

Assembly Instructions

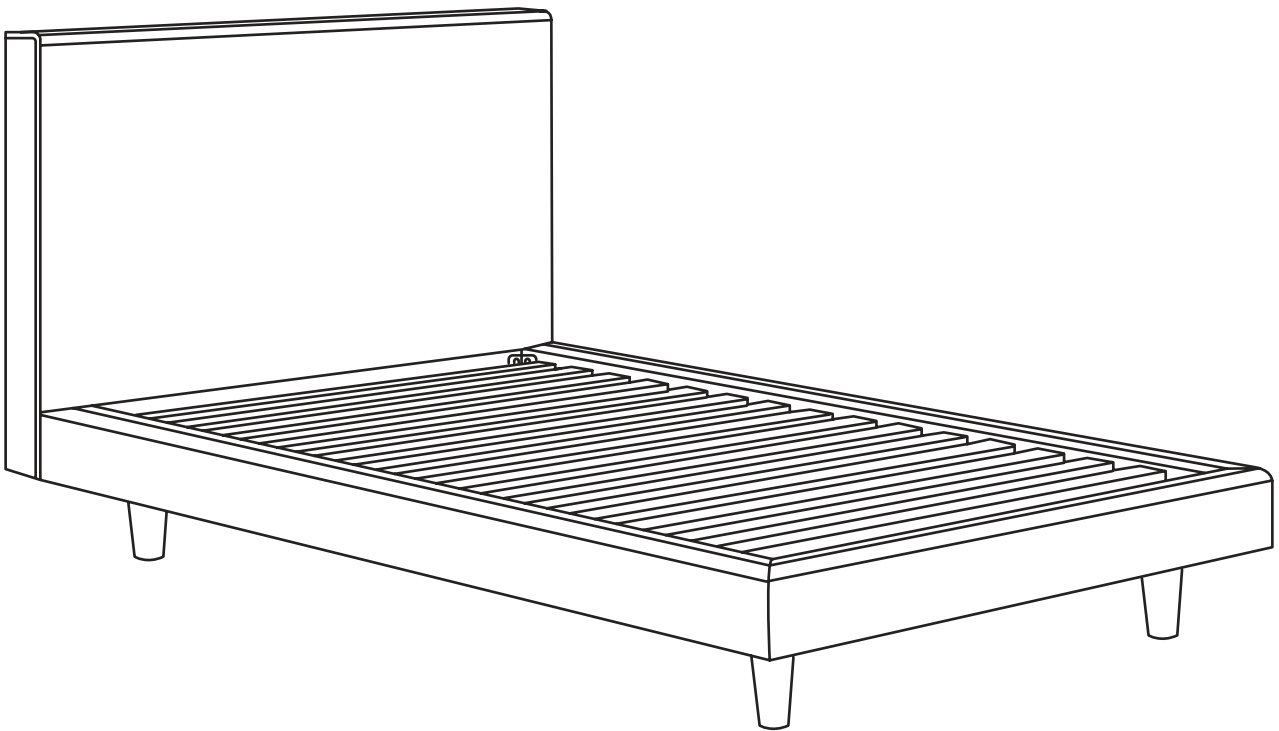

TESSU

Full Bed

ASSEMBLY INSTRUCTIONS

Read these instructions carefully and keep for future reference. Refer to parts inventory for guidance, and ensure you have all pieces before starting.

When assembling, place all parts on a soft, clean, and flat surface such as a carpet to prevent scratches.

If you're having difficulty, our friendly Customer Care team is always here to help. Call us at **1.888.746.3455** during business hours, email service@article.com or chat live at [article.com](https://www.article.com).



TIME





OF PEOPLE

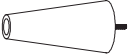
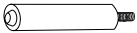

DIFFICULTY

PARTS INVENTORY		
ID	DESCRIPTION	QTY
A	FOOTBOARD	1
B	RIGHT SIDE RAIL	1
C	LEFT SIDE RAIL	1
D	HEADBOARD	1
E	CORNER LEG 	4
F	CORNER LEG FRAME	4
G	CENTER FLOATING LEG 	1
G	CENTER FRAME	1
I	SLATS	4

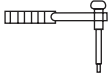
PARTS INVENTORY CONT.		
ID	DESCRIPTION	QTY
J	M8 WASHER 	44
K	M8 LOCK WASHER 	44
L	M8 x 40MM BOLT 	44
M	MINI RATCHET WRENCH 	1

1

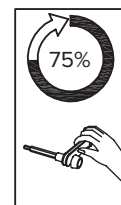
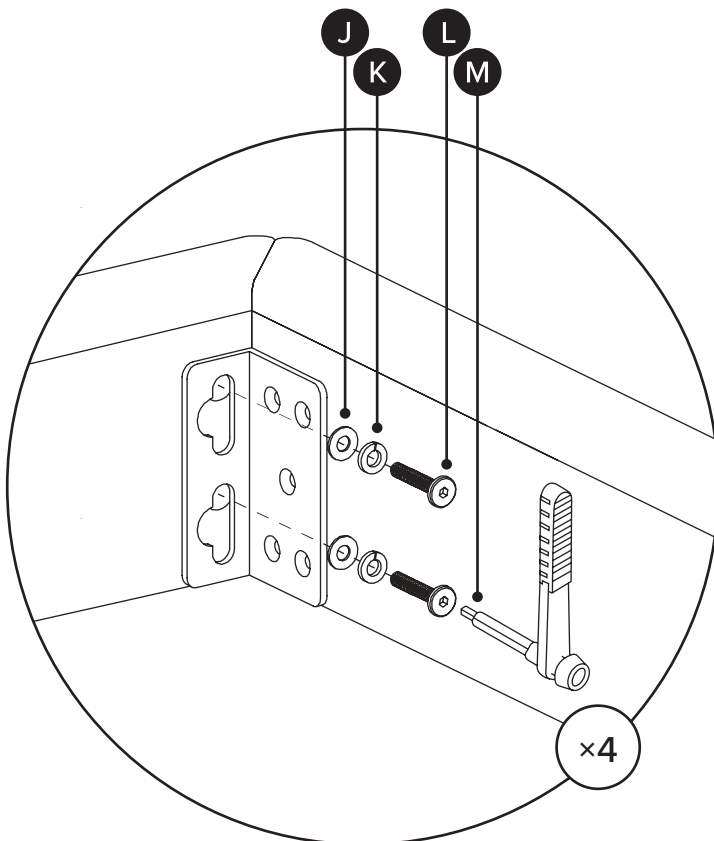
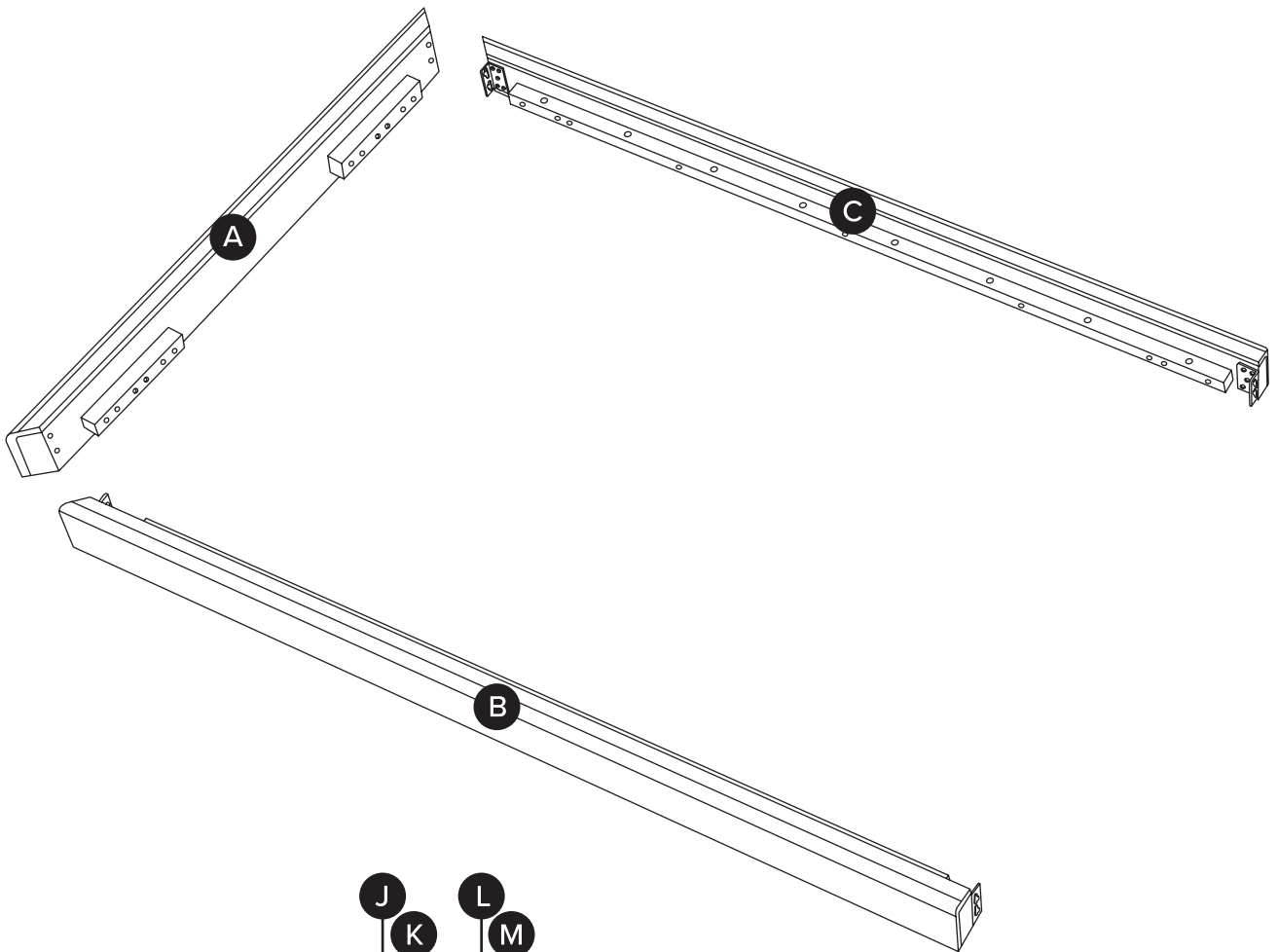

! Turn bolts (L) by hand first.
Do not fully tighten bolts (L)
on corner frames until step 2.

2

! Make sure to level the right side frame and left side frame metal brackets at 90 degree angle before attaching to the headboard.

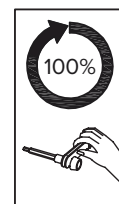
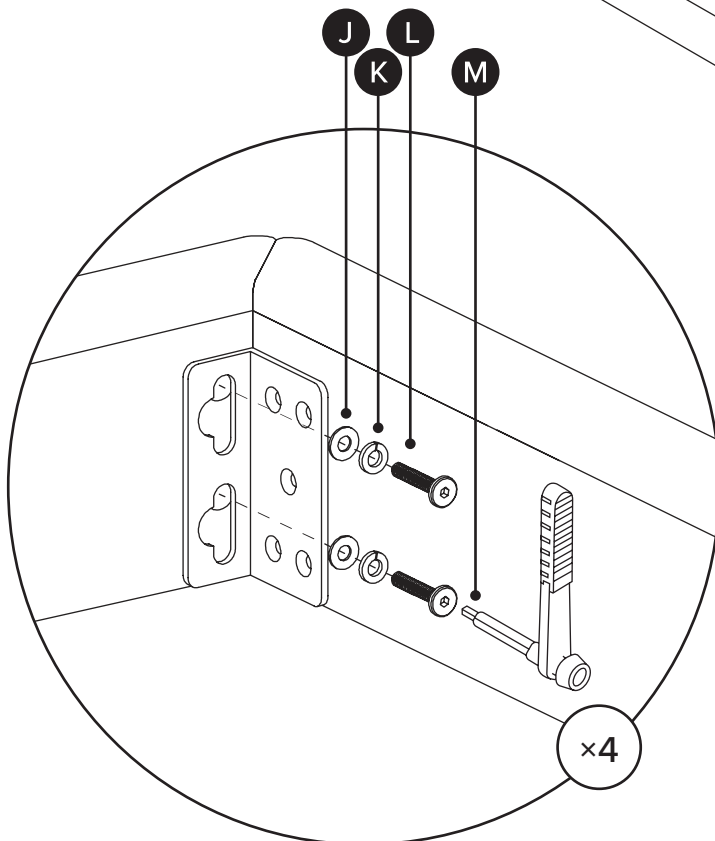
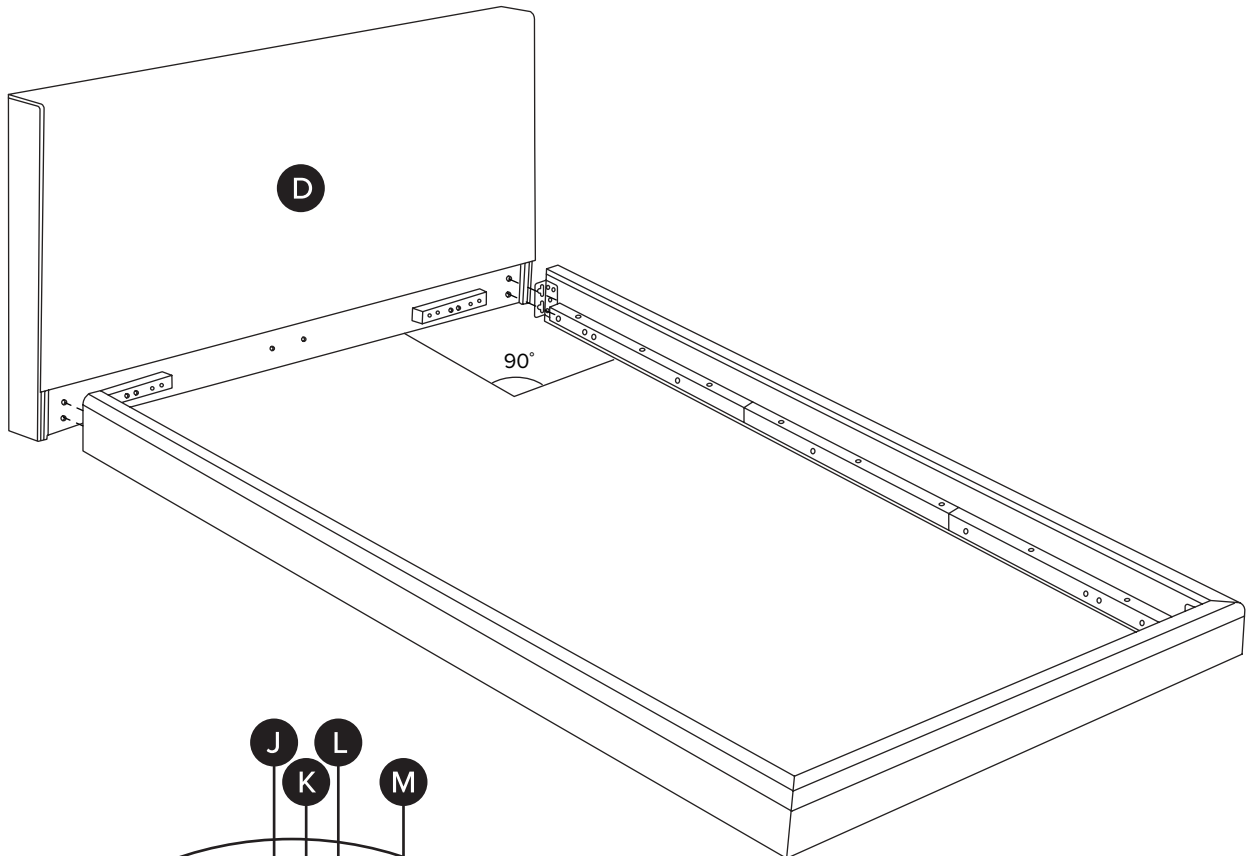

! Turn bolts (L) by hand first. Fully tighten bolts (L) on corner frames after the side rails are flat.

3

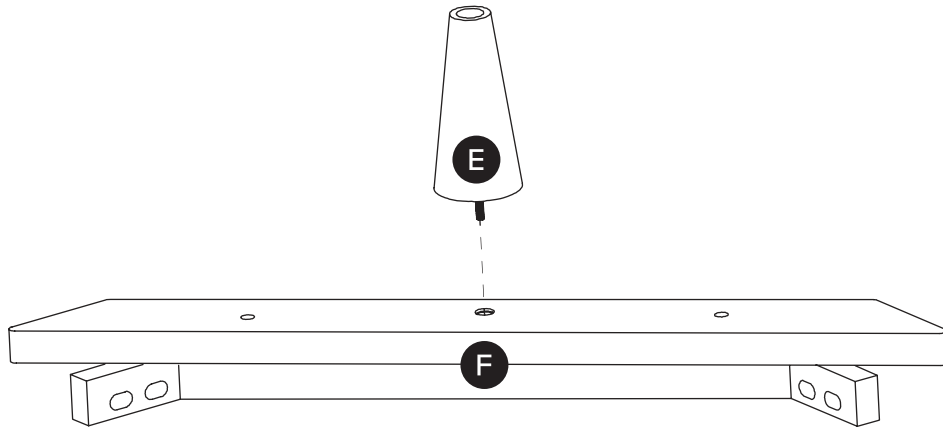

4

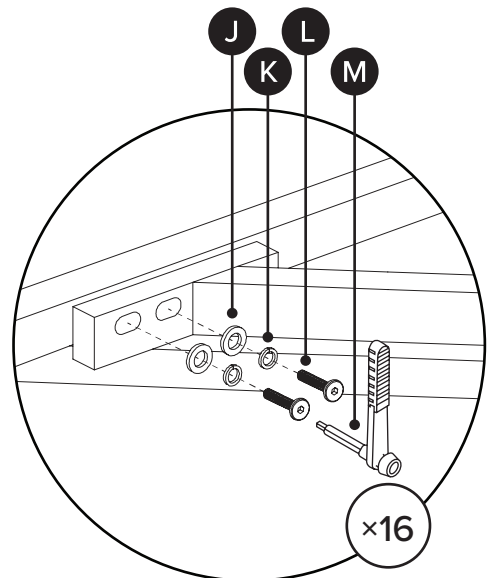
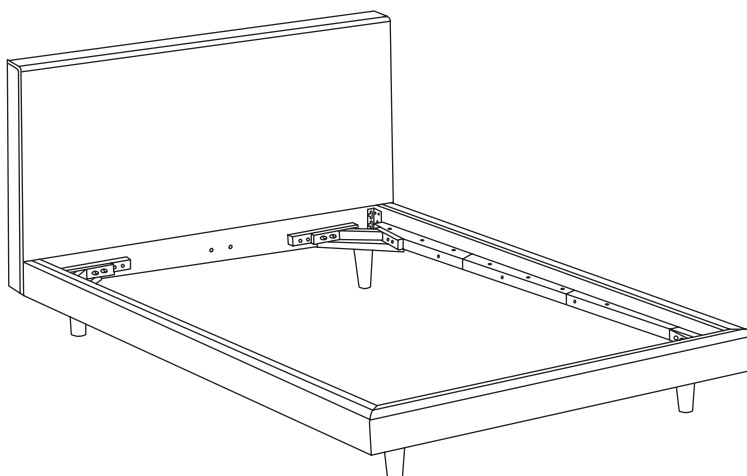

! Do not fully tighten bolts (L) on corner leg frames (F) until step 8.

5

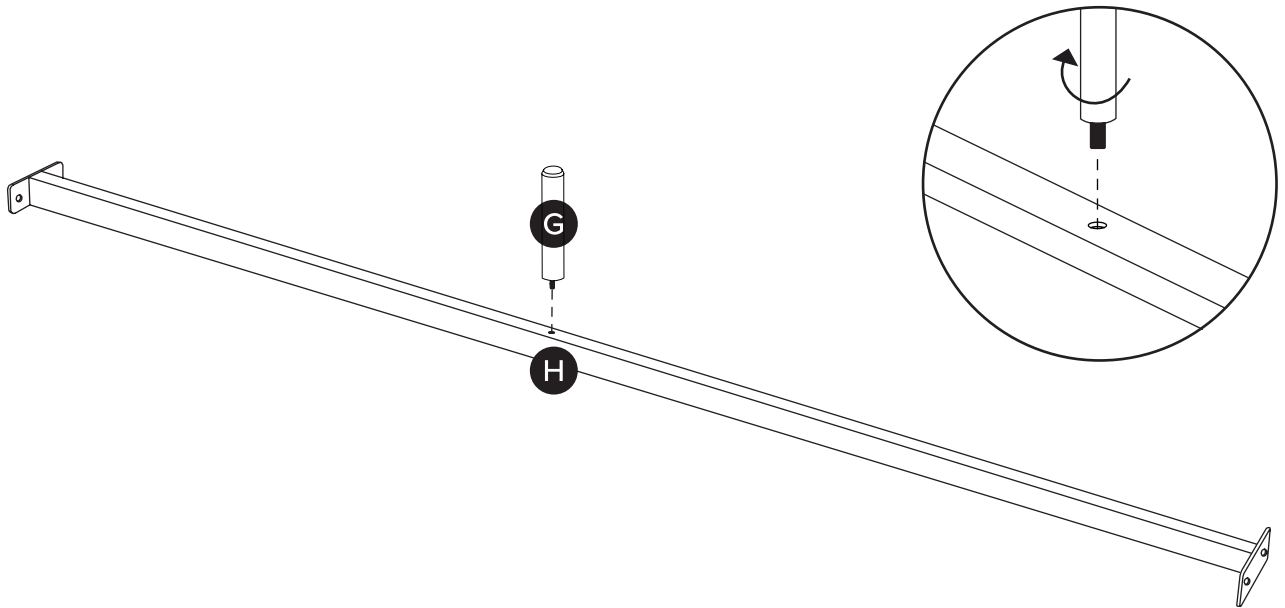

6

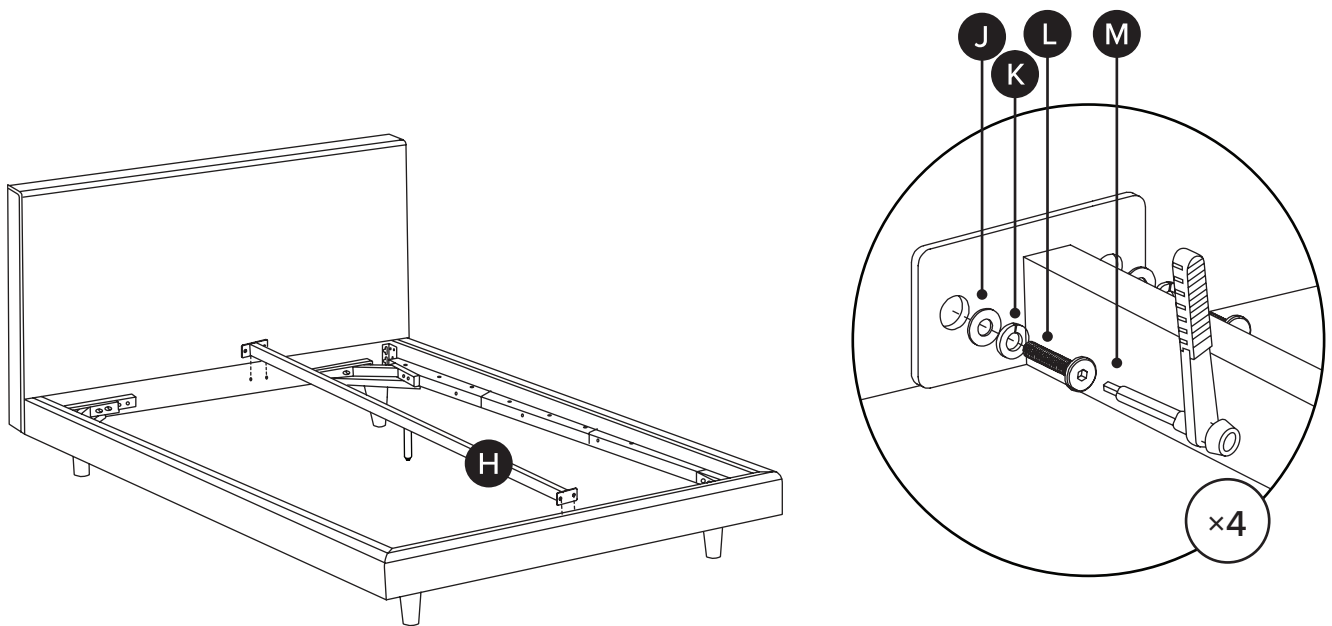

7

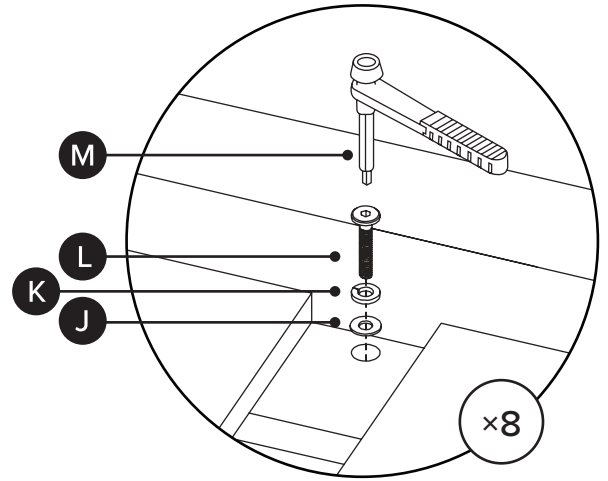
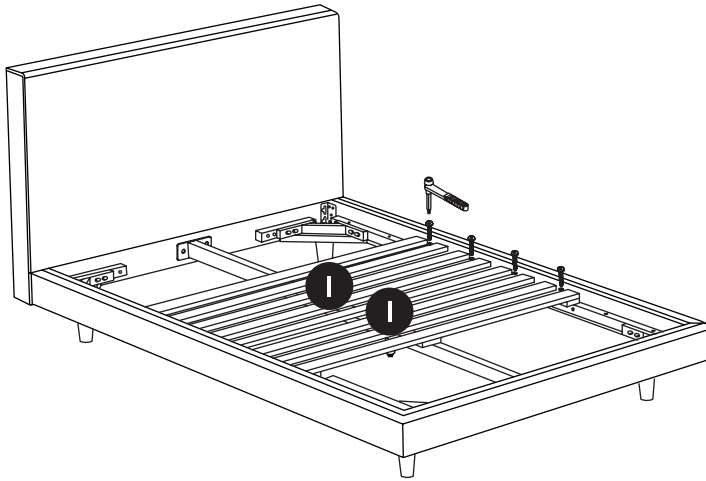

! Install 2 slats in the middle first.

8

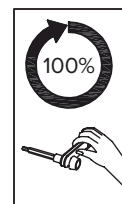
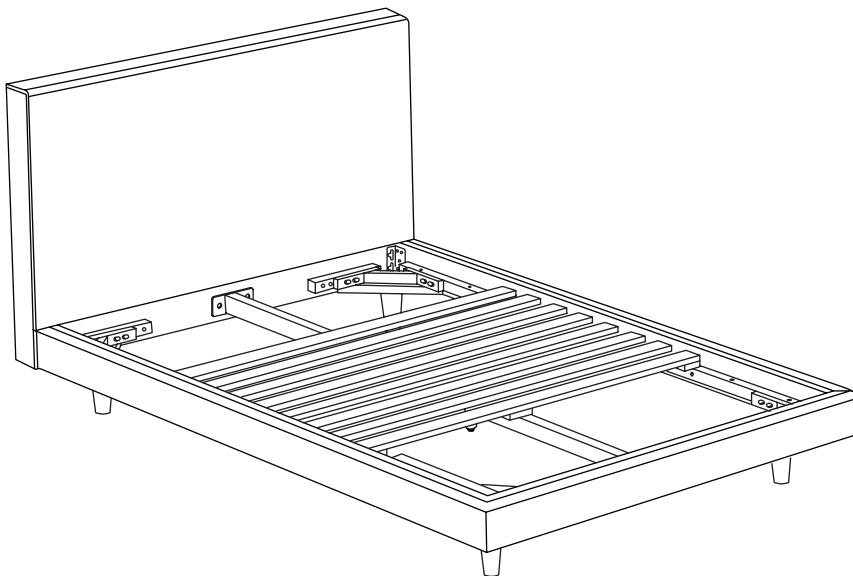

! Fully tighten all bolts on corner leg frames once central slats are installed.

9

