

ARTICLE.

VERSION 1.1

Assembly Instructions

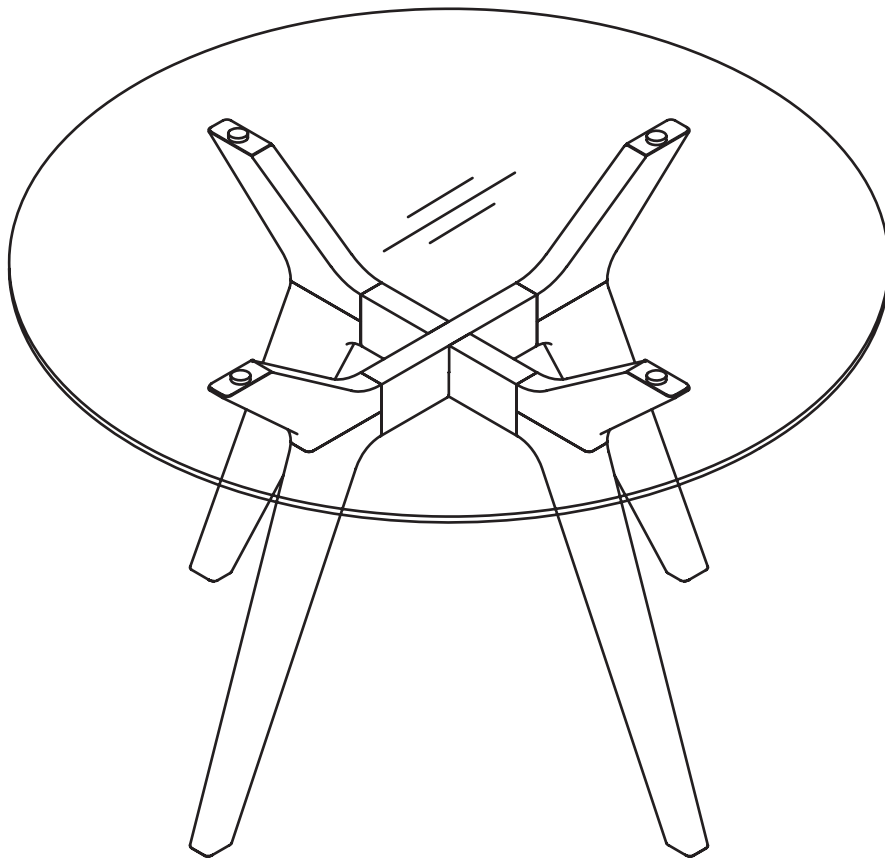

EMMER

Round Dining Table

ASSEMBLY INSTRUCTIONS

Read these instructions carefully and keep for future reference. Refer to parts inventory for guidance, and ensure you have all pieces before starting.

When assembling, place all parts on a soft, clean, and flat surface such as a carpet to prevent scratches.

If you're having difficulty, our friendly Customer Care team is always here to help. Call us at **1.888.746.3455** during business hours, email service@article.com or chat live at [article.com](https://www.article.com).

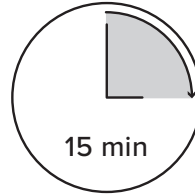

TIME

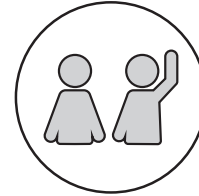



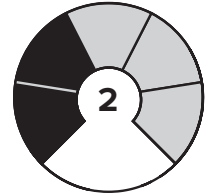



OF PEOPLE



DIFFICULTY

PARTS INVENTORY		
ID	DESCRIPTION	QTY
1	LEG FRAME	1
2	LEG FRAME	1
3	GLASS TABLE TOP	1
4	CROSS PLATE	1

PARTS INVENTORY CONT.		
ID	DESCRIPTION	QTY
A	M6X30 MM BOLT 	8
B	M6X50 MM BOLT 	1
C	SPRING WASHER 	5
D	FLAT WASHER 	5
E	ALLEN KEY 	1
F	M8X20 MM BOLT 	4

1

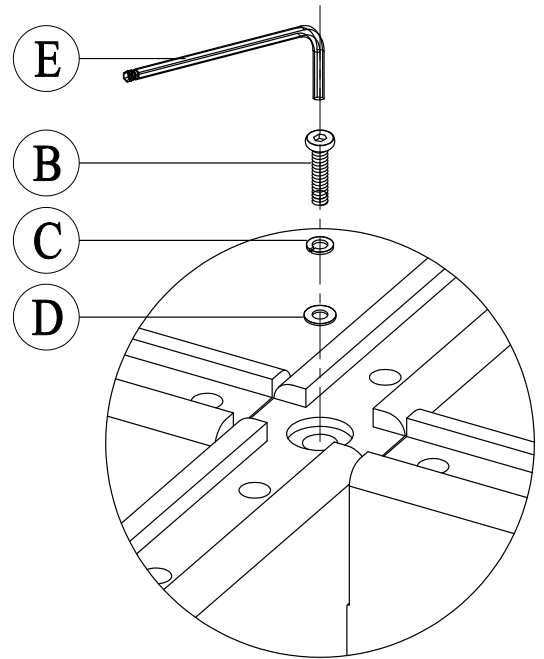
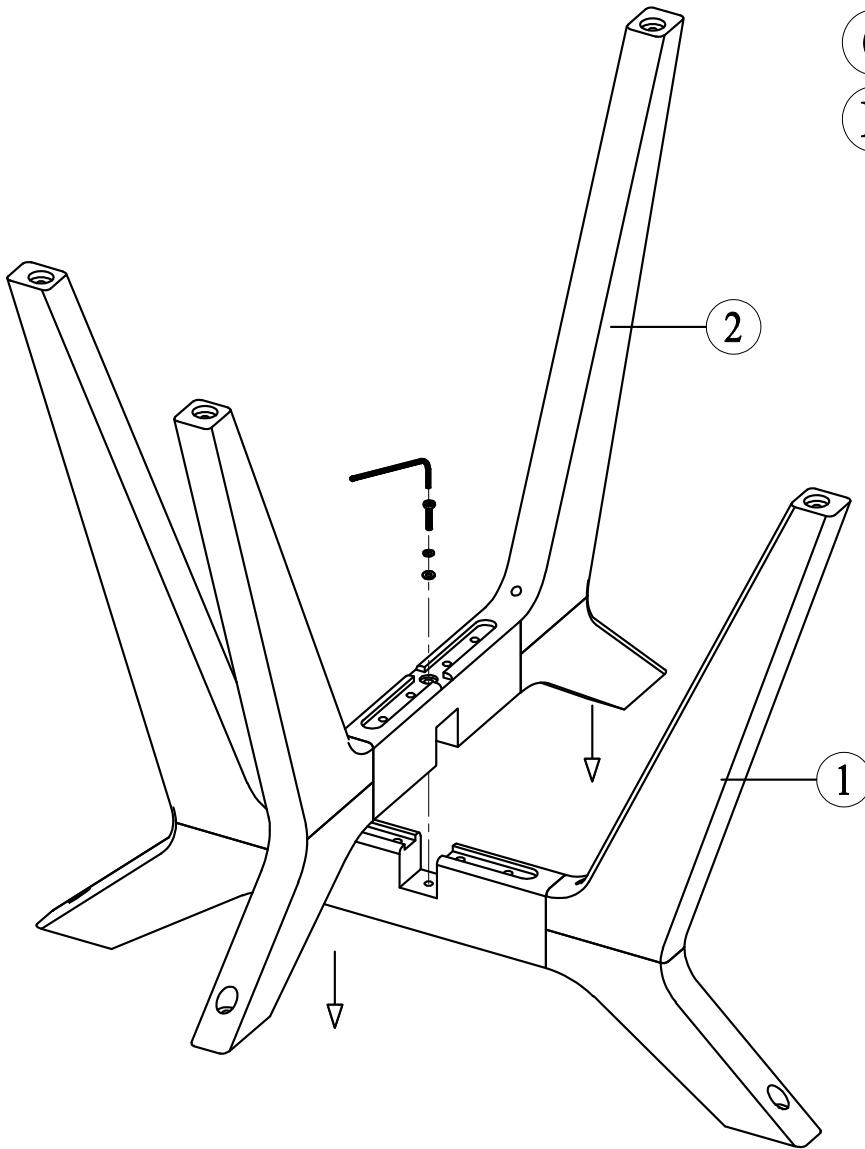

Tighten the bolt 100 %

2

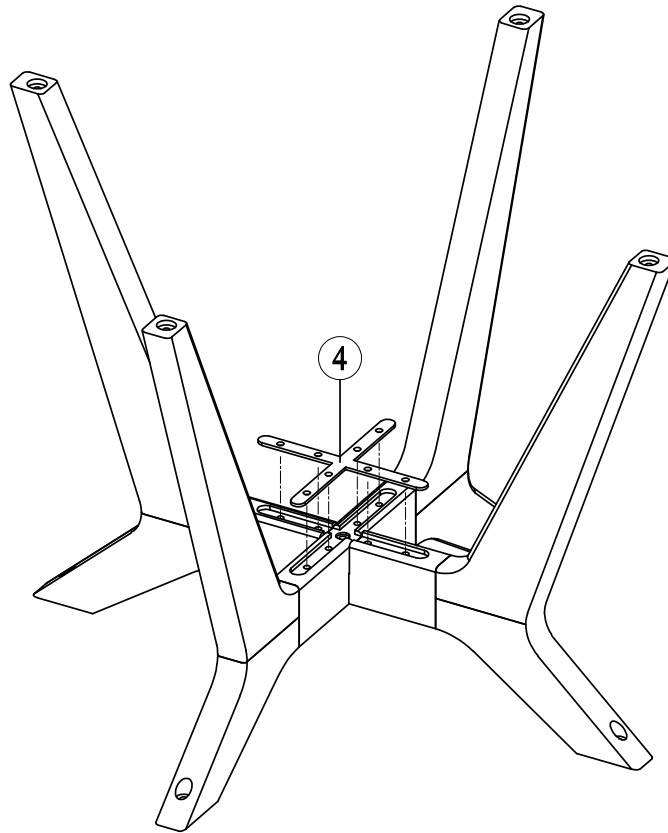

3

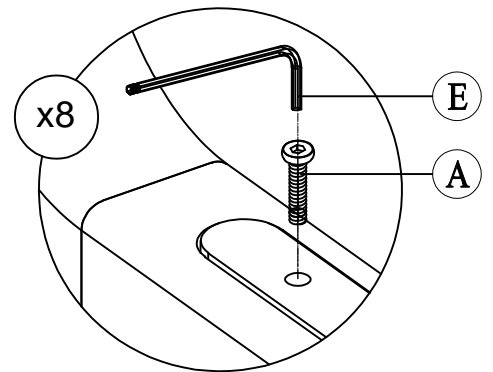
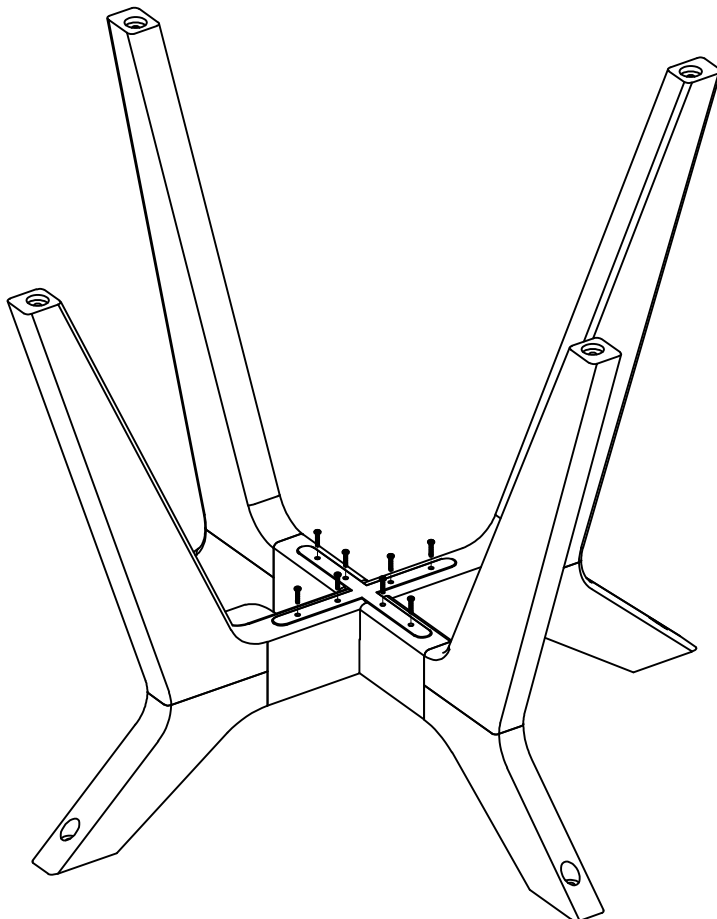

Do not tighten all bolts
Max 75 %

4

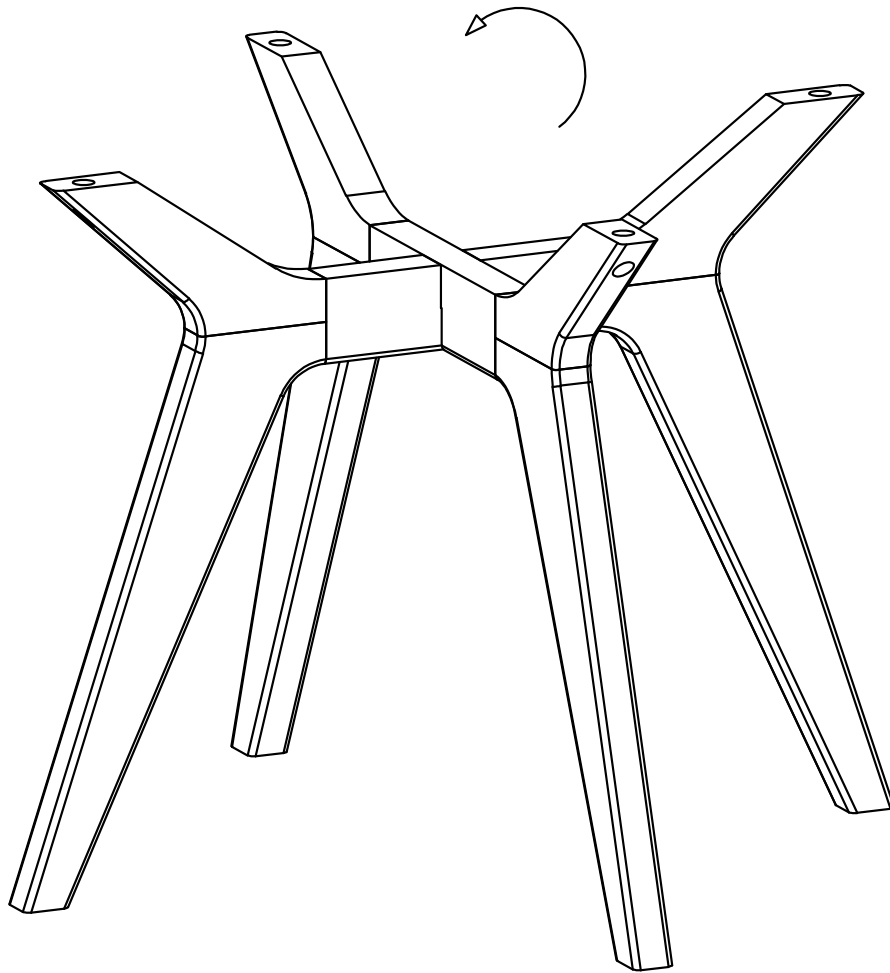

5

Place Aluminum cup into the Legs hole

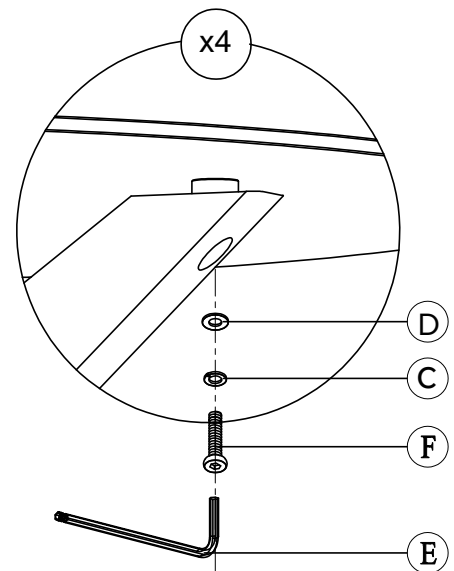
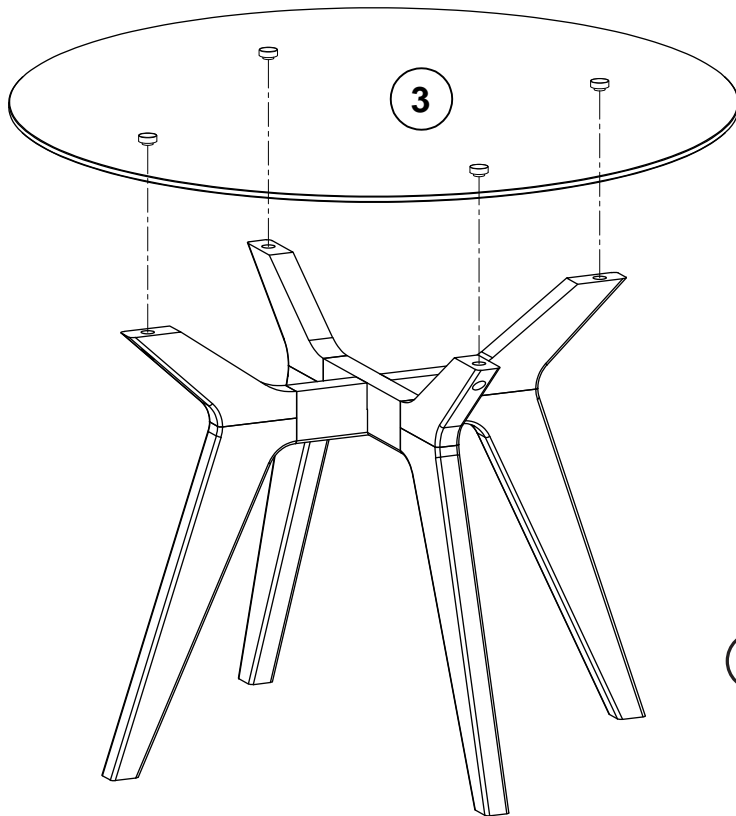

! Fully tighten all bolts

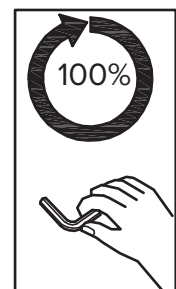

6

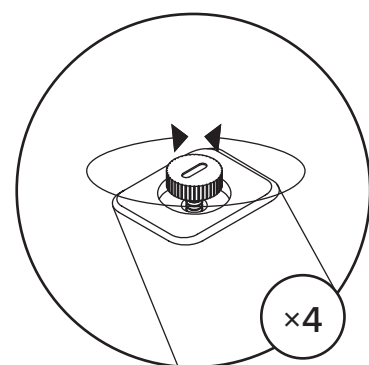
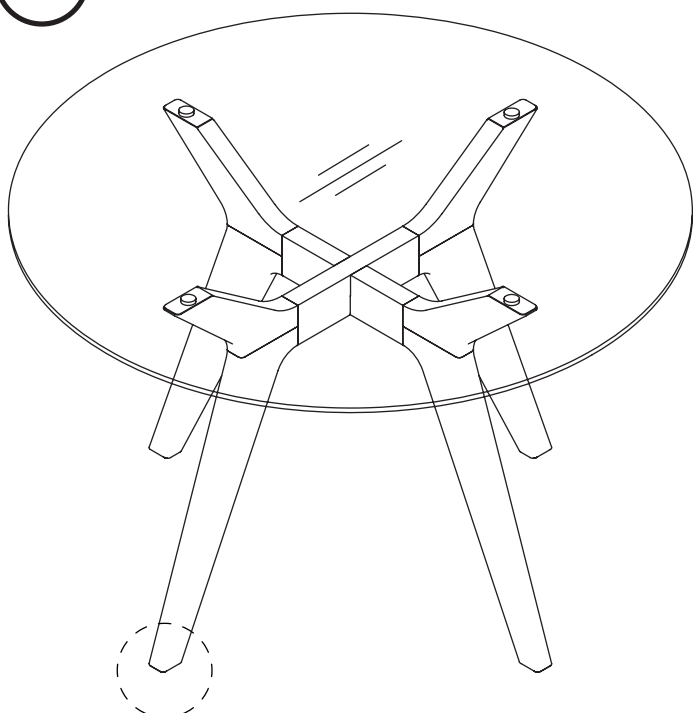

! Adjust levelers on legs as needed.

! Structural integrity is warranted only if all fasteners are properly installed & tightened. The glass top is placed and maintained at the right position as per instructions.