

ARTICLE.

VERSION 1.2

Assembly Instructions

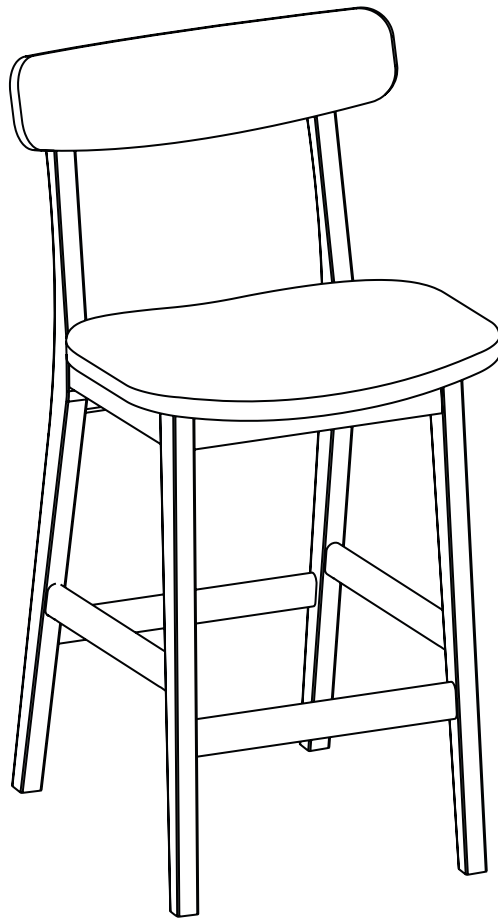

ECOLE

Counter Stool

ASSEMBLY INSTRUCTIONS

Read these instructions carefully and keep for future reference. Refer to parts inventory for guidance, and ensure you have all pieces before starting.

When assembling, place all parts on a soft, clean, and flat surface such as a carpet to prevent scratches.

If you're having difficulty, our friendly Customer Care team is always here to help. Call us at **1.888.746.3455** during business hours, email service@article.com or chat live at [article.com](https://www.article.com).

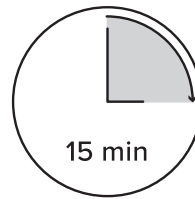







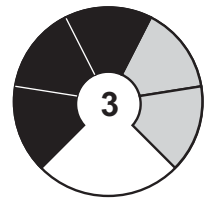

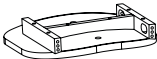

TIME



OF PEOPLE

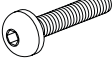
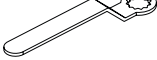

DIFFICULTY

PARTS INVENTORY		
ID	DESCRIPTION	QTY
A	CHAIR SEAT 	1
B	CHAIR BACK 	1
C	FRONT LEG 	1
D	SIDE BAR 	2
E	M6 × 10MM LOCK WASHER 	4
F	M6 × 12MM WASHER 	4
G	M8 × 70MM PIN 	4
H	13 × 30MM HALF MOON WASHER 	4
I	M8 NUT 	4
J	M6 × 40MM BOLT 	4
K	SPANNER 	1
L	ALLEN KEY 	1

1

Use your hand to attach the Pin (G) all the way into the Front leg (C)

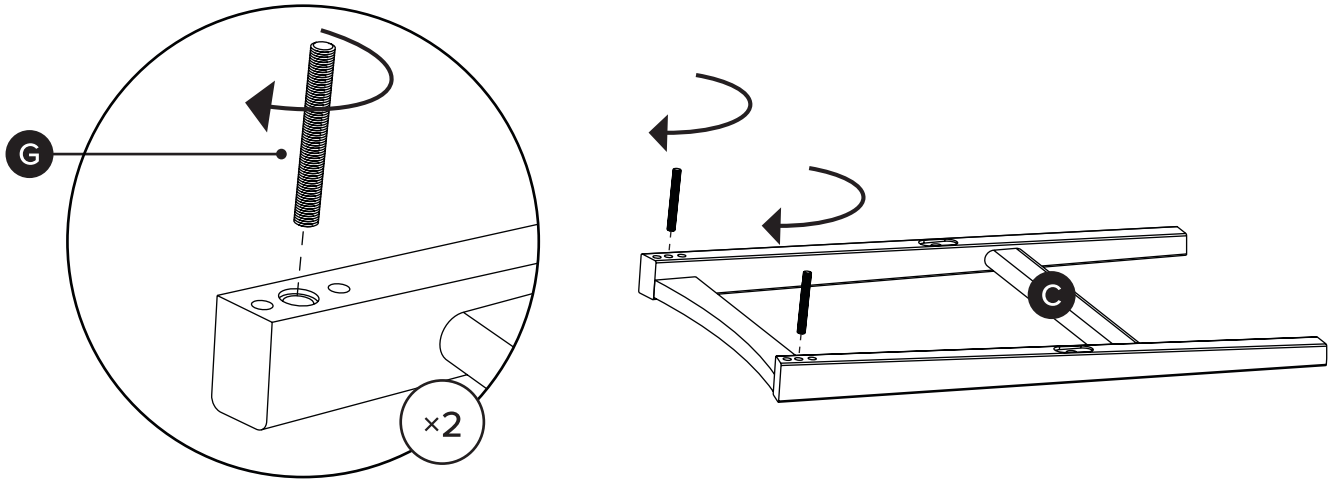

2

Use your hand to attach the Pin (G) all the way into the Back leg (B)

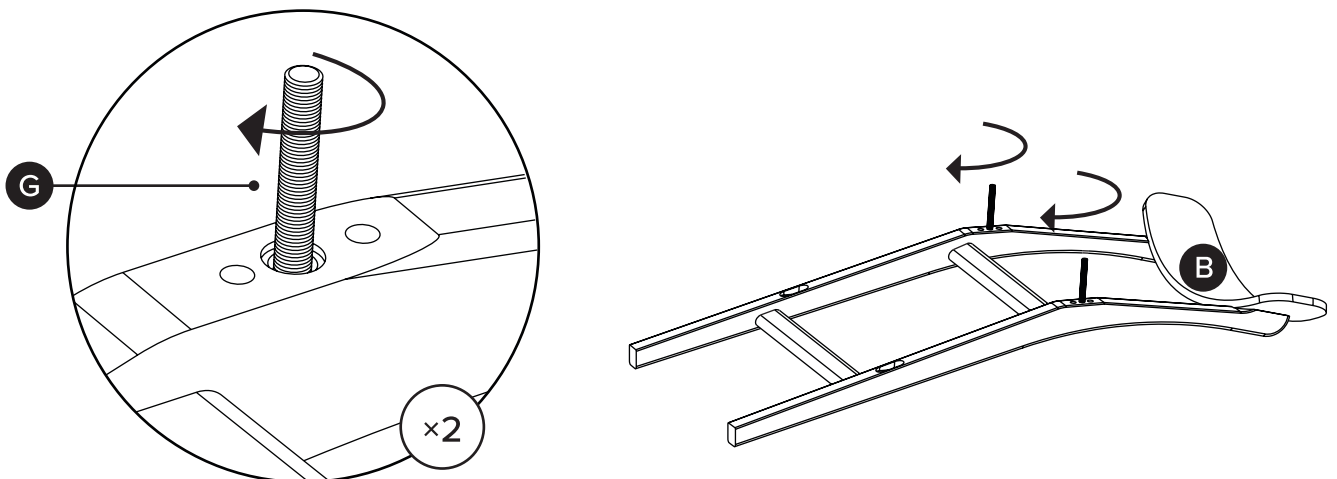

3

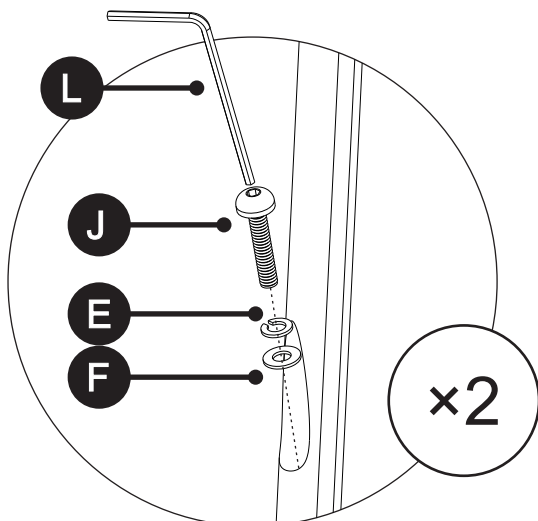
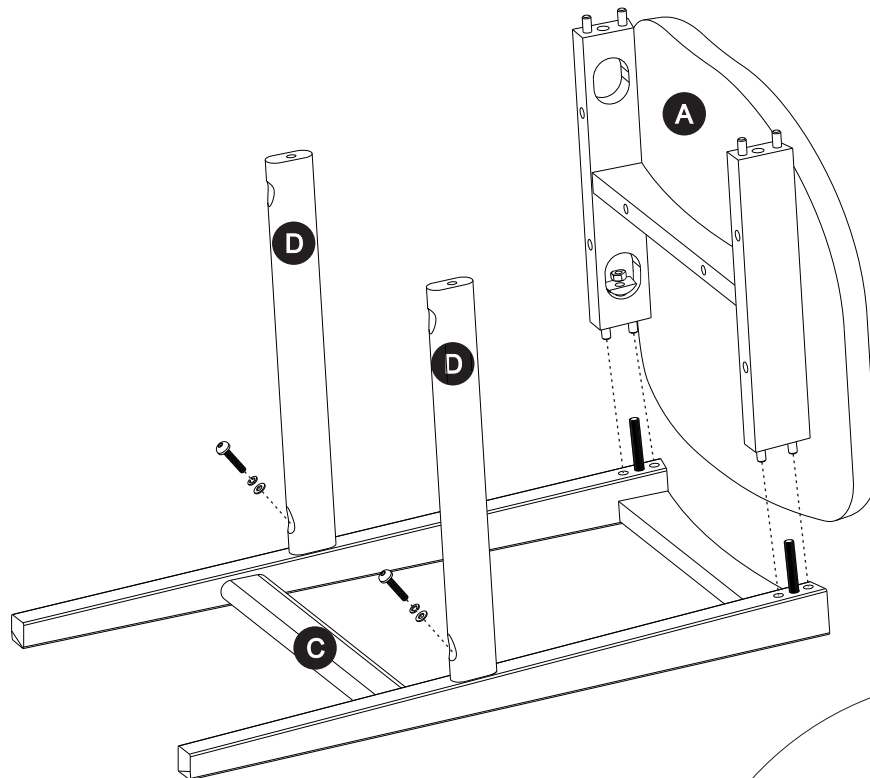

Use Allen Key (L) to attach the Bolt (J) and Washers (E+F) to Side Bar (D) to 80%

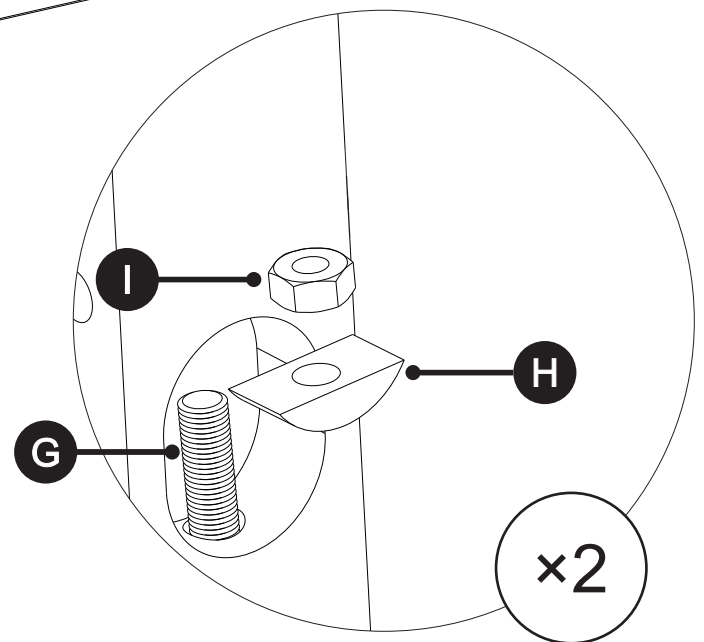

Use your hand to attach the Nut (I) and Half moon washer (H) to Pin (G)



! Tighten all Bolts (J) with Allen Key (L) and Nut (I) with Spanner (K) to 80%

4

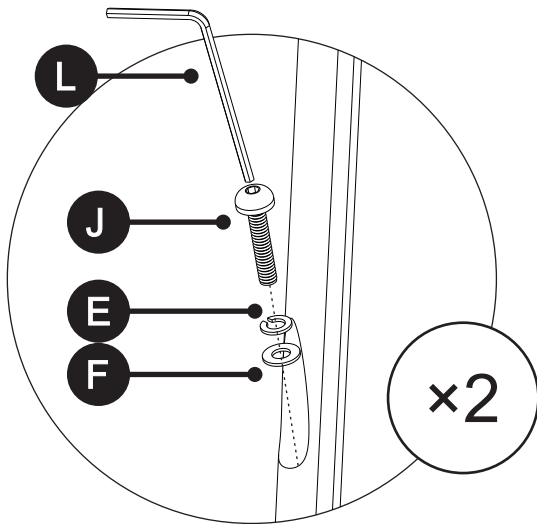
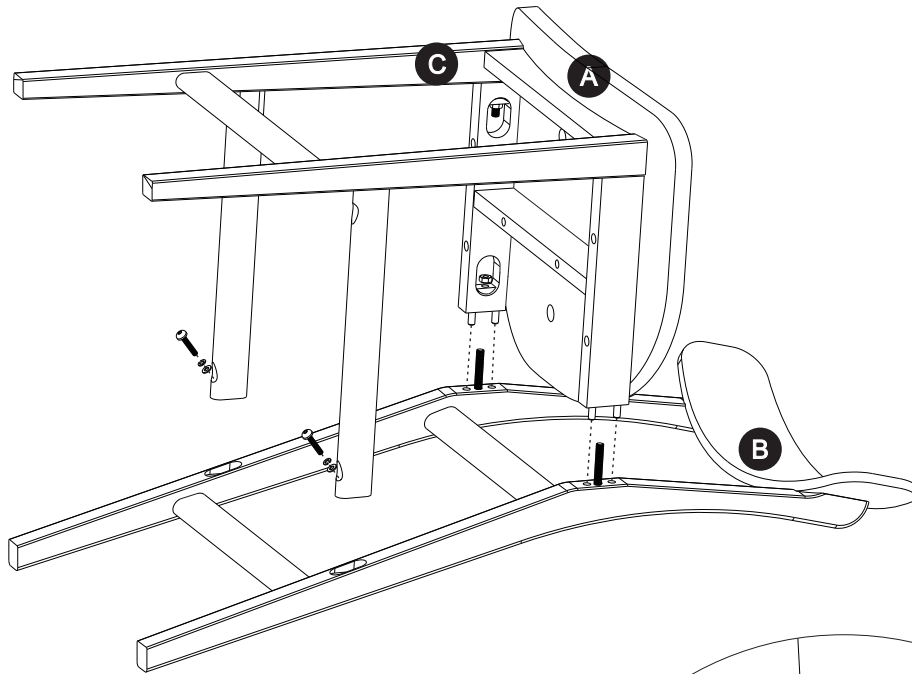

Use Allen Key (L) to attach the Bolt (J) and Washers (E+F) to Side Bar (D) to 80%

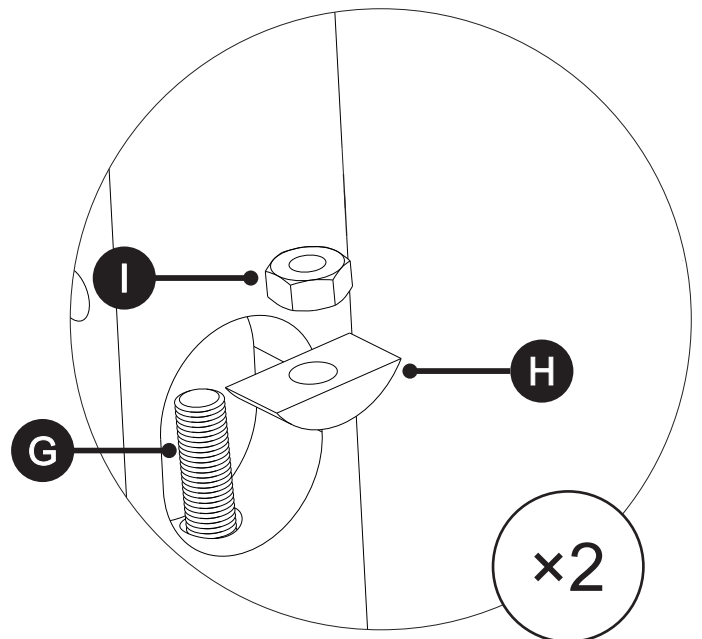

Use your hand to attach the Nut (I) and Half moon washer (H) to Pin (G)

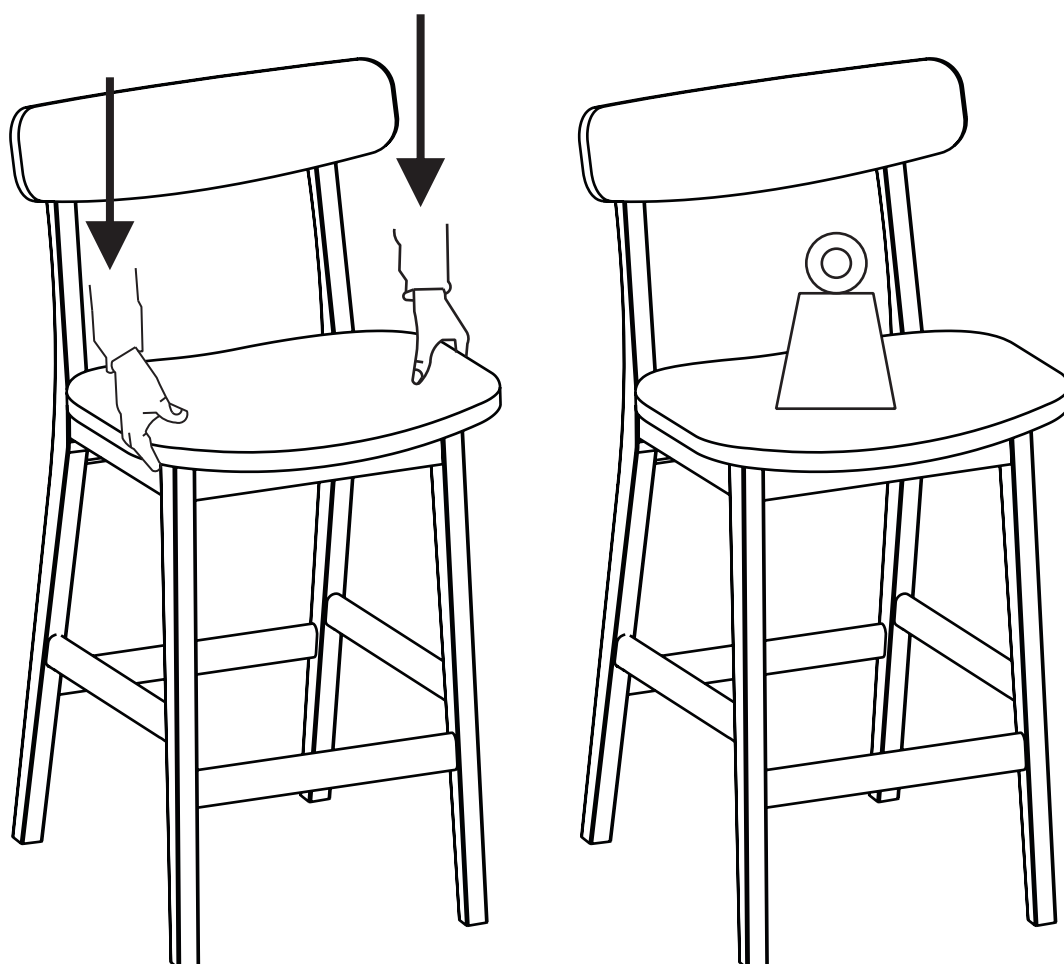

! Tighten all Bolts (J) with Allen Key (L) and Nut (I) with Spanner (K) to 80%

5 — LEG STABILITY

! To ensure all 4 legs are flat with the floor please place a weight on the seat or manually push downwards until the 4 legs are flat with the floor before tighten all screws 100%

6

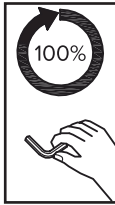

! Tighten all Bolts (J) with Allen Key (L) and Nut (I) with Spanner (K) 100%

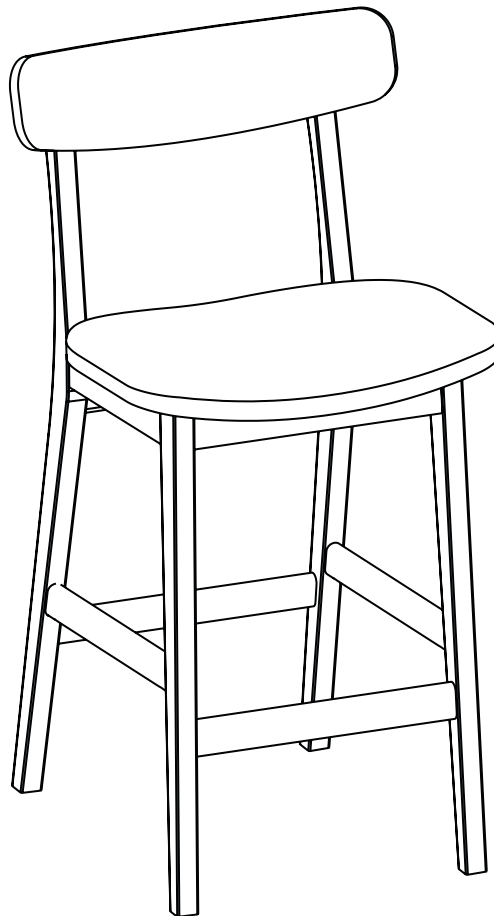

! It is important that all bolts are retightened 2 weeks after assembly and once every 2 months in order to assure stability throughout the lifespan of this product.