

# ARTICLE.

VERSION 1.0

## Assembly Instructions

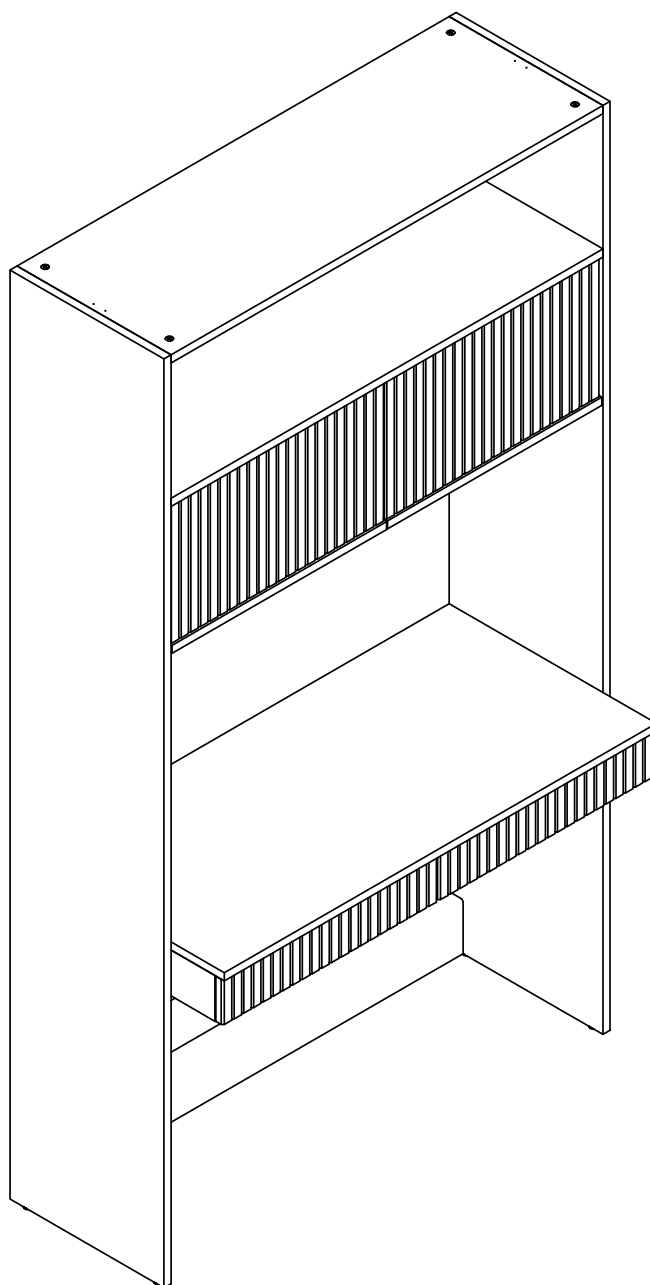

# KOUVA

Modular Wall Desk

## ASSEMBLY INSTRUCTIONS

Read these instructions carefully and keep for future reference. Refer to parts inventory for guidance, and ensure you have all pieces before starting.

When assembling, place all parts on a soft, clean, and flat surface such as a carpet to prevent scratches.

If you're having difficulty, our friendly Customer Care team is always here to help. Call us at **1.888.746.3455** during business hours, email [service@article.com](mailto:service@article.com) or chat live at [article.com](http://article.com).

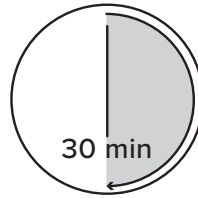

TIME



# OF PEOPLE

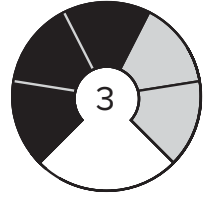









DIFFICULTY



**ANTI-TIP**  
Installation Required

PARTS INVENTORY		
ID	DESCRIPTION	QTY
<b>A</b>	TOP PANEL	1
<b>B</b>	TOP STORAGE	1
<b>C</b>	DESK TOP	1
<b>D</b>	BACK PANEL	1
<b>E</b>	BOTTOM STRETCHER	1
<b>FL</b>	LEFT SIDE PANEL	1
<b>FR</b>	RIGHT SIDE PANEL	1

PARTS INVENTORY		
ID	DESCRIPTION	QTY
<b>G</b>	ALLEN KEY 	2
<b>H</b>	M6 x 30MM BOLT 	24
<b>I</b>	M6 x 50MM BOLT 	4
<b>J</b>	M6 LOCK WASHER 	28
<b>K</b>	M6 WASHER 	24
<b>L</b>	HALF MOON WASHER 	4
<b>M</b>	CAM LOCK 	6
<b>N</b>	CAM BOLT 	6

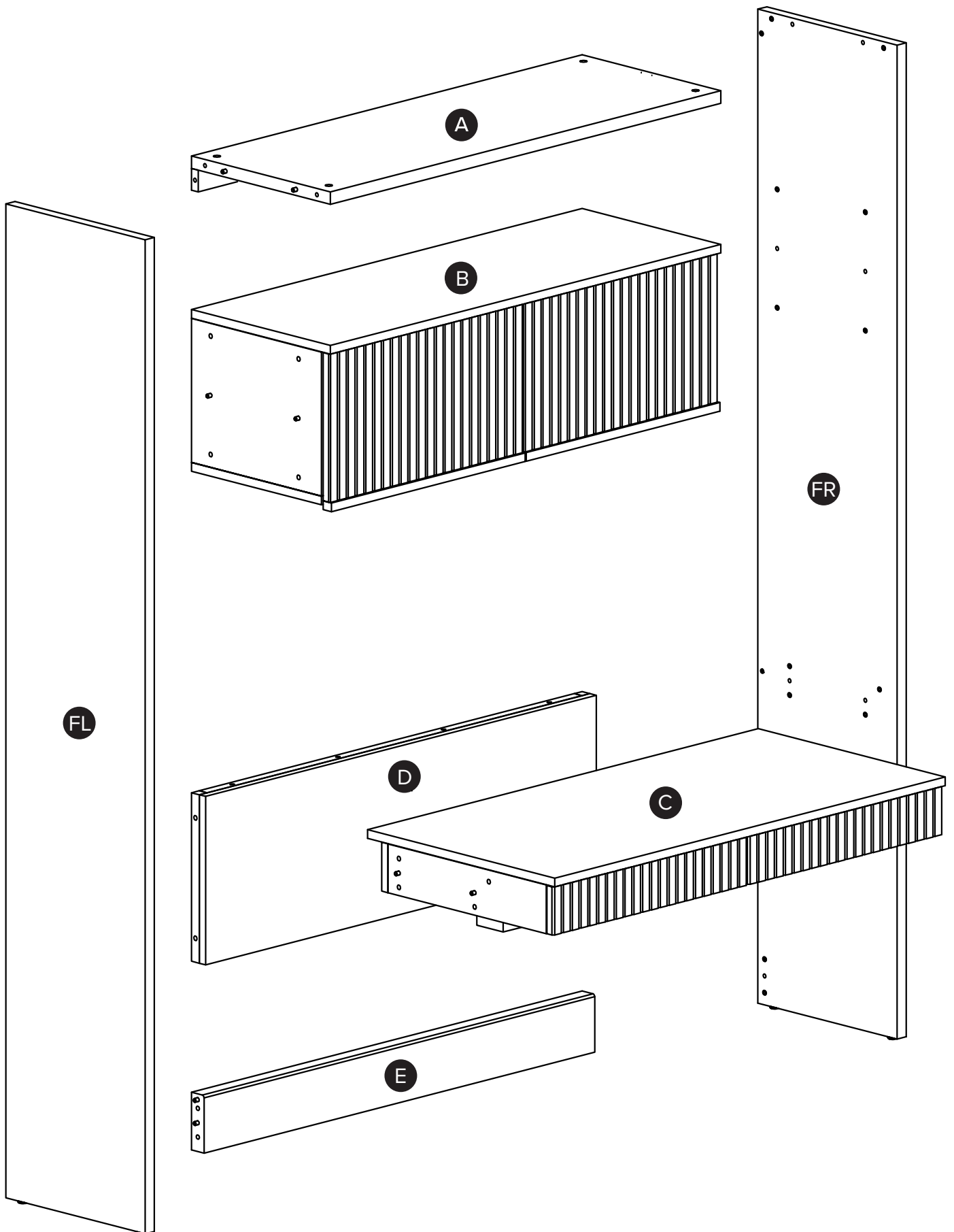

1

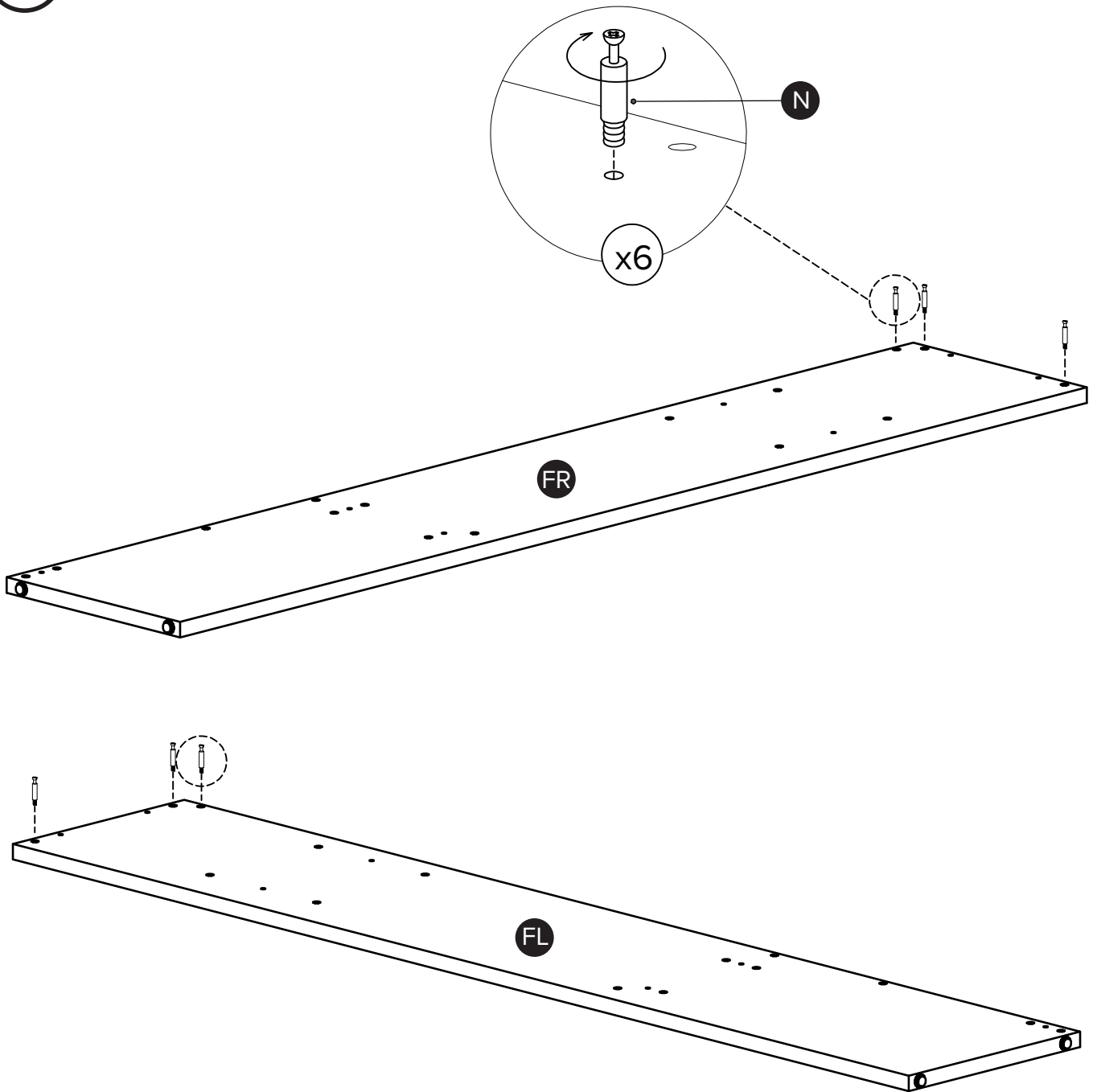

! Please ensure to put components on a flat and soft surface such as a cardboard or a rug.

2

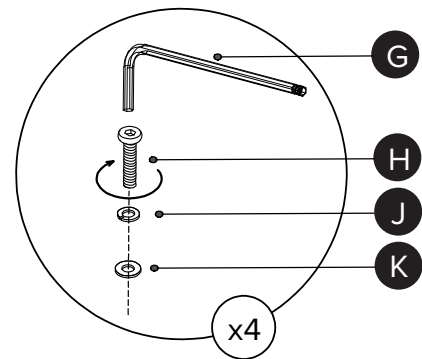
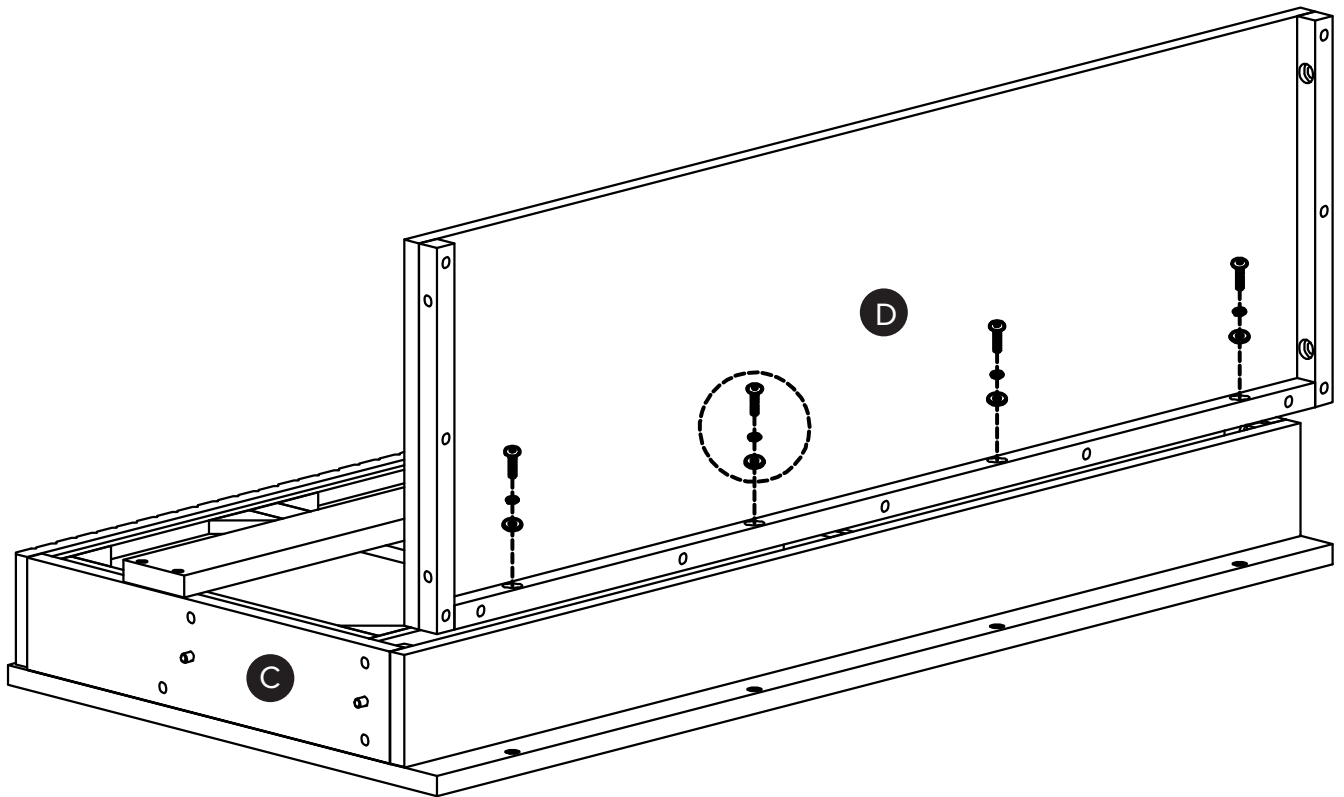
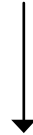

3

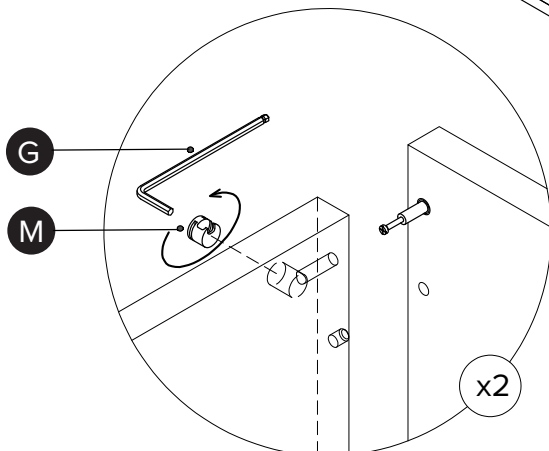
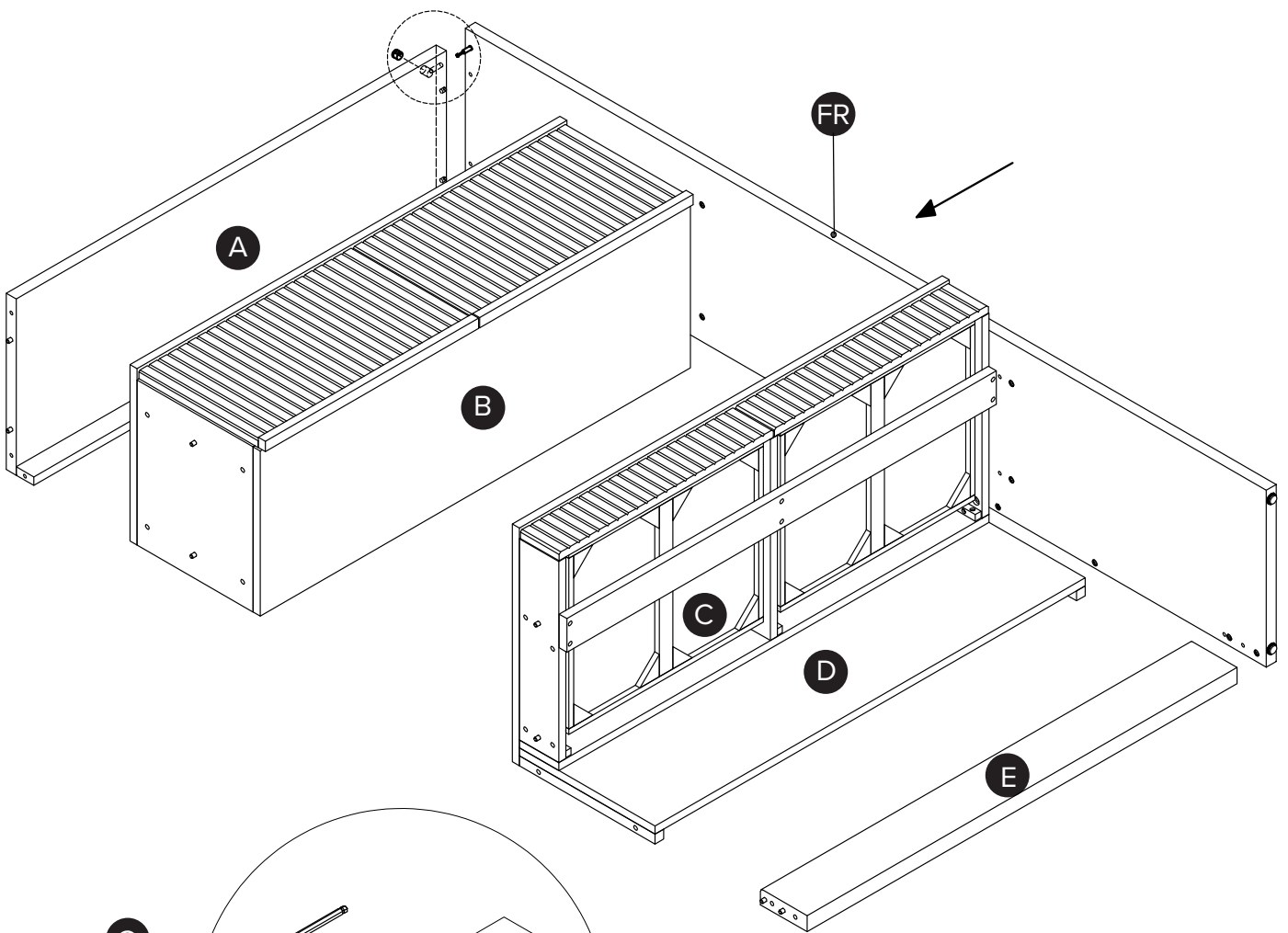
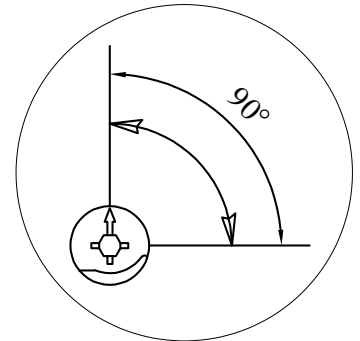

4

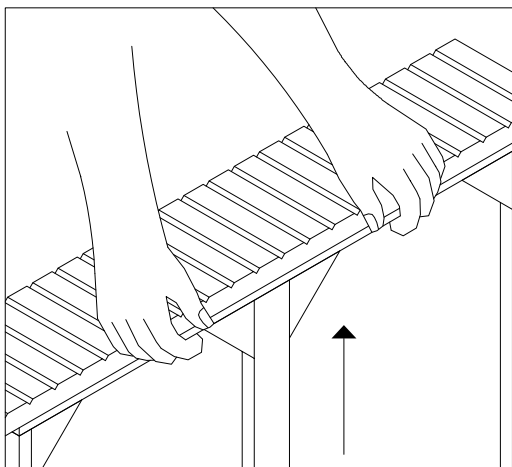
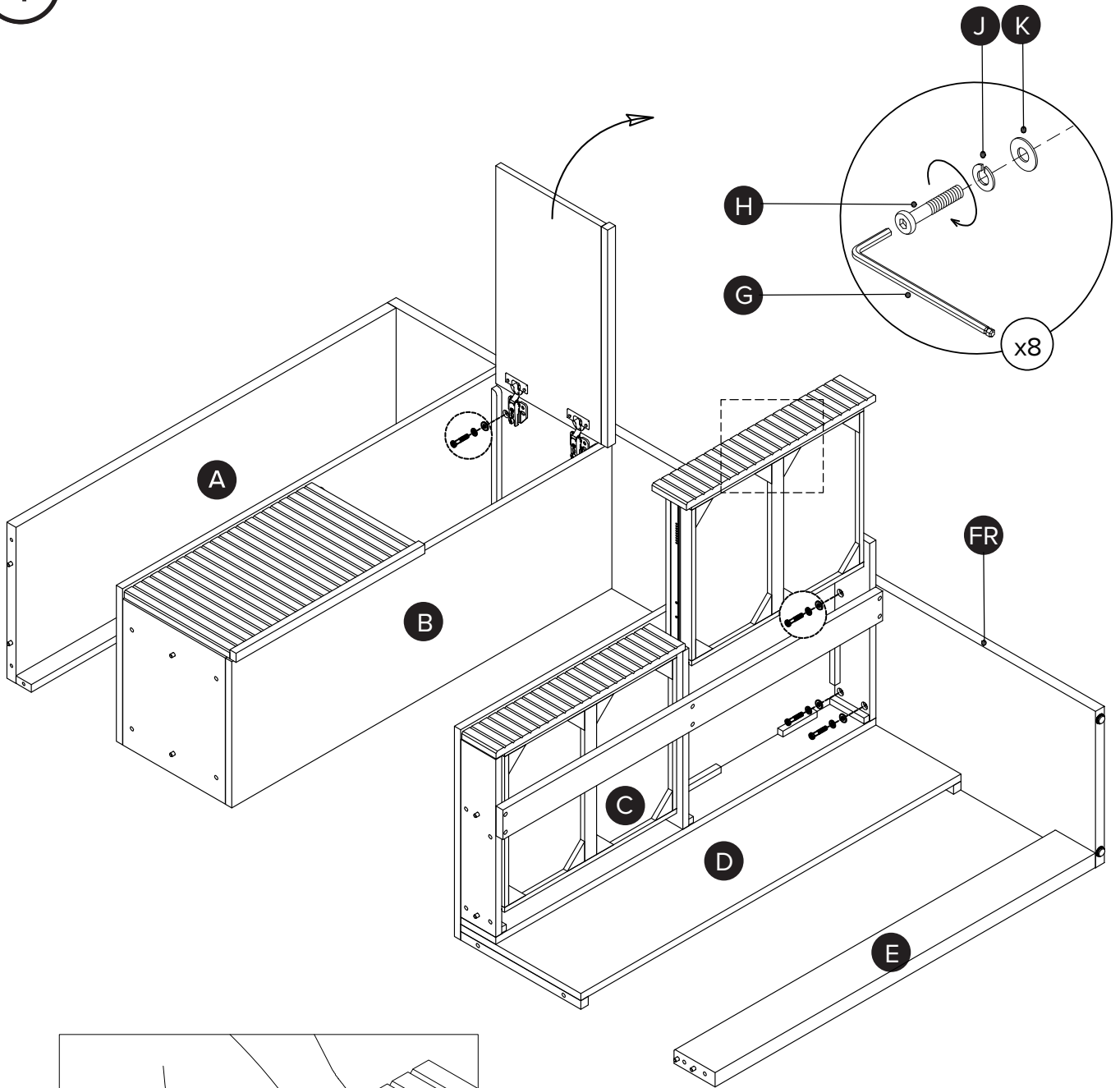

5

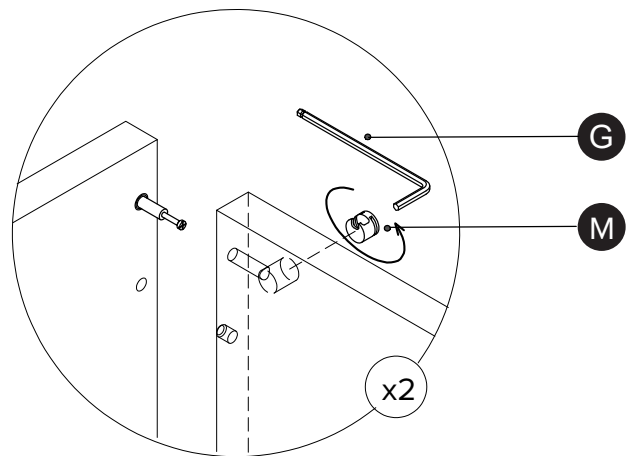
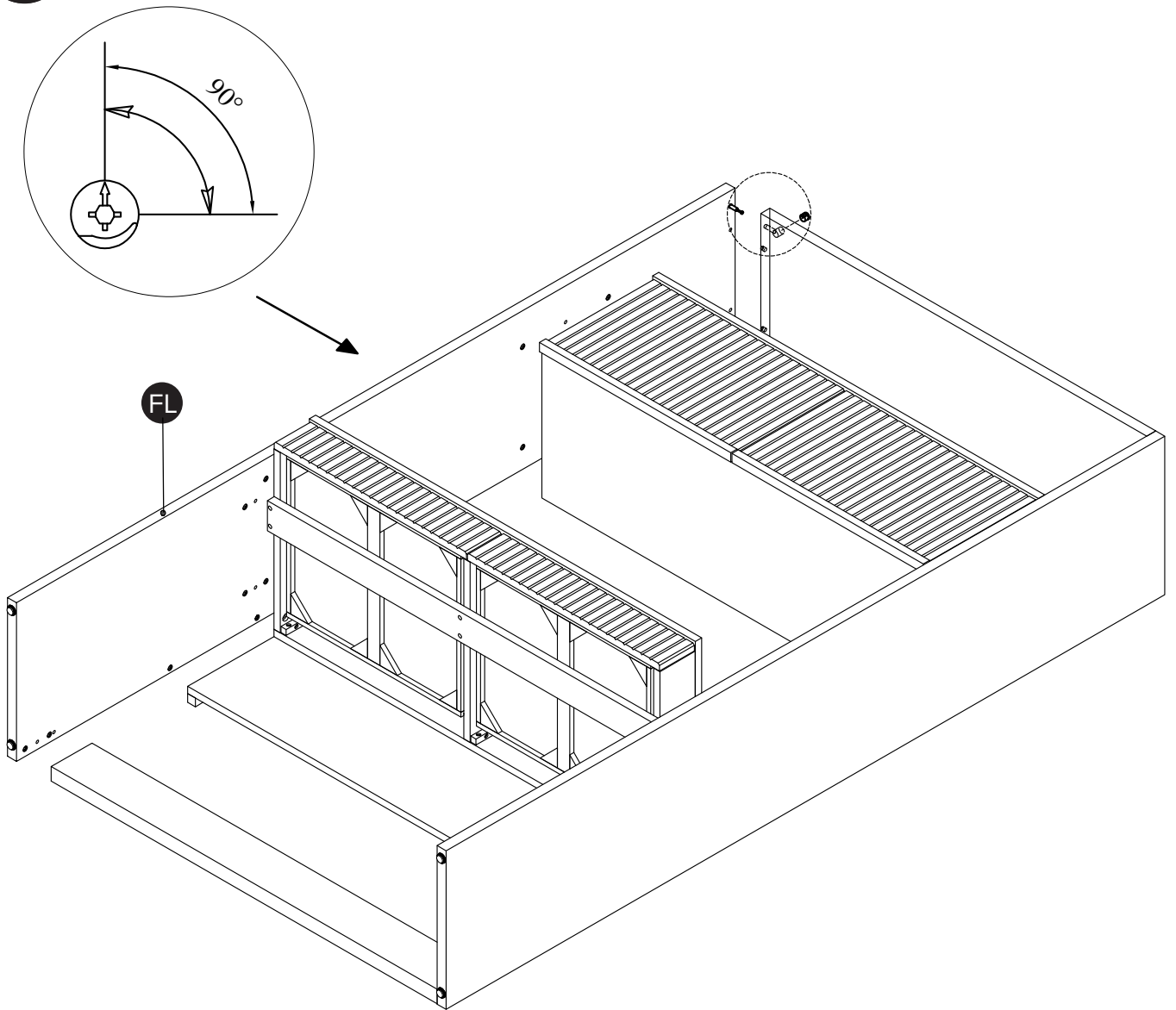



6

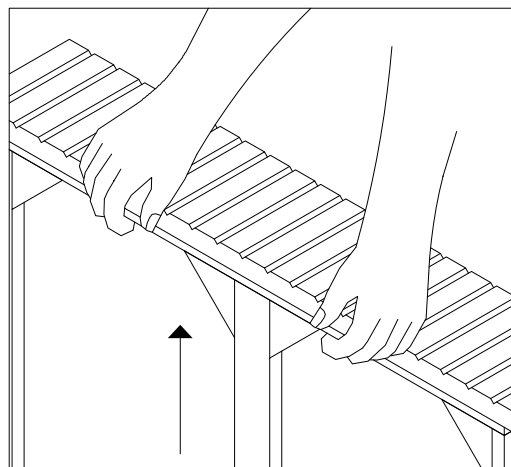
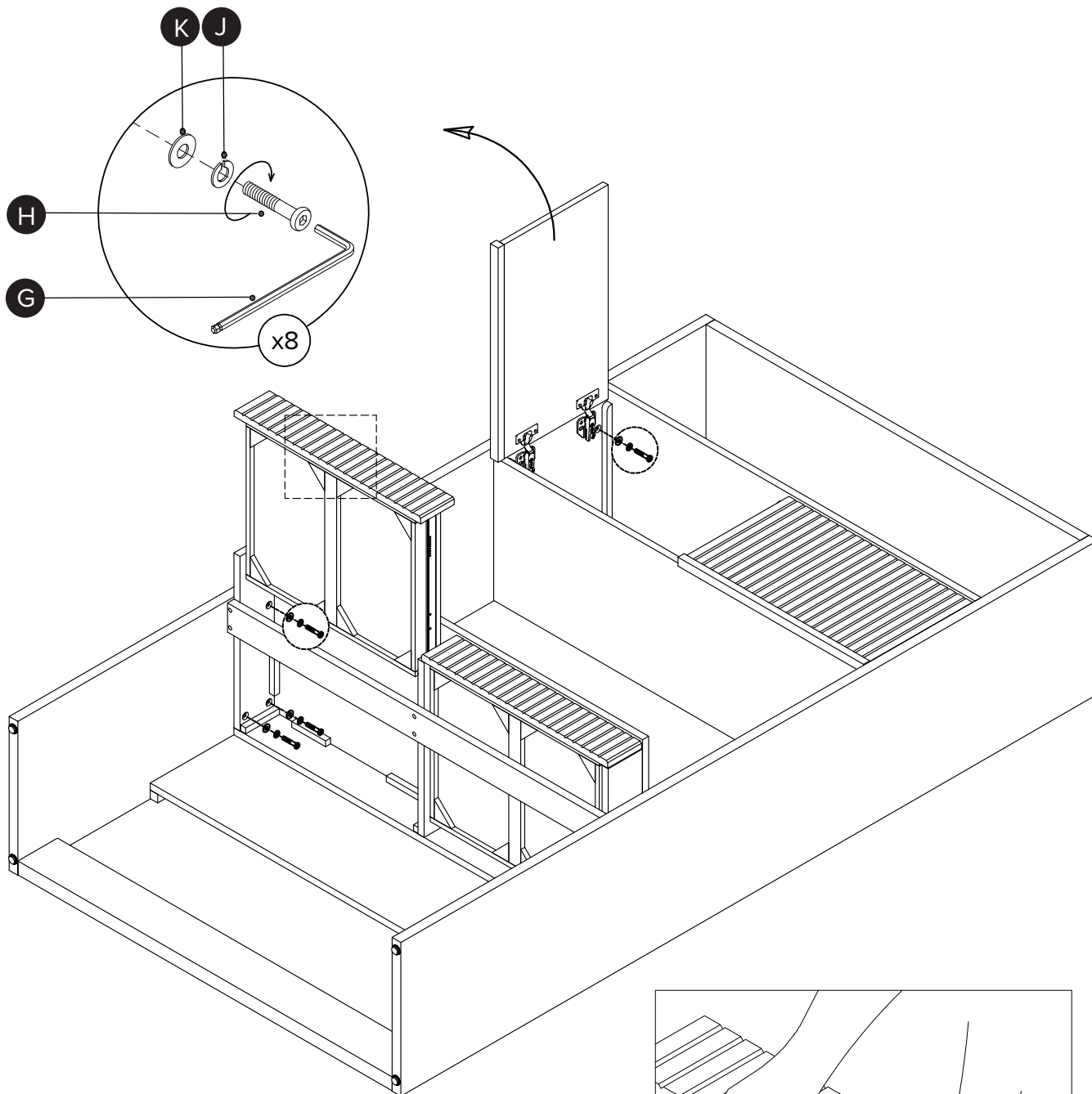

**!** CAUTION!

Please take care when lifting, this unit is heavy!

7

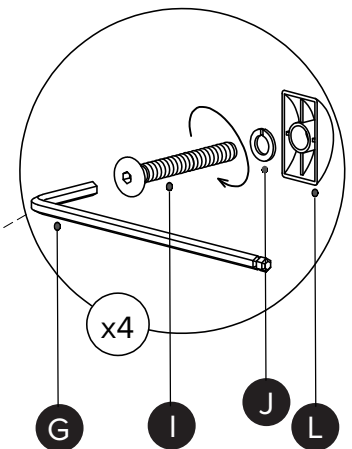
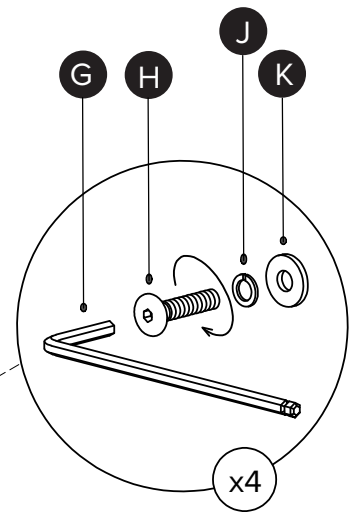
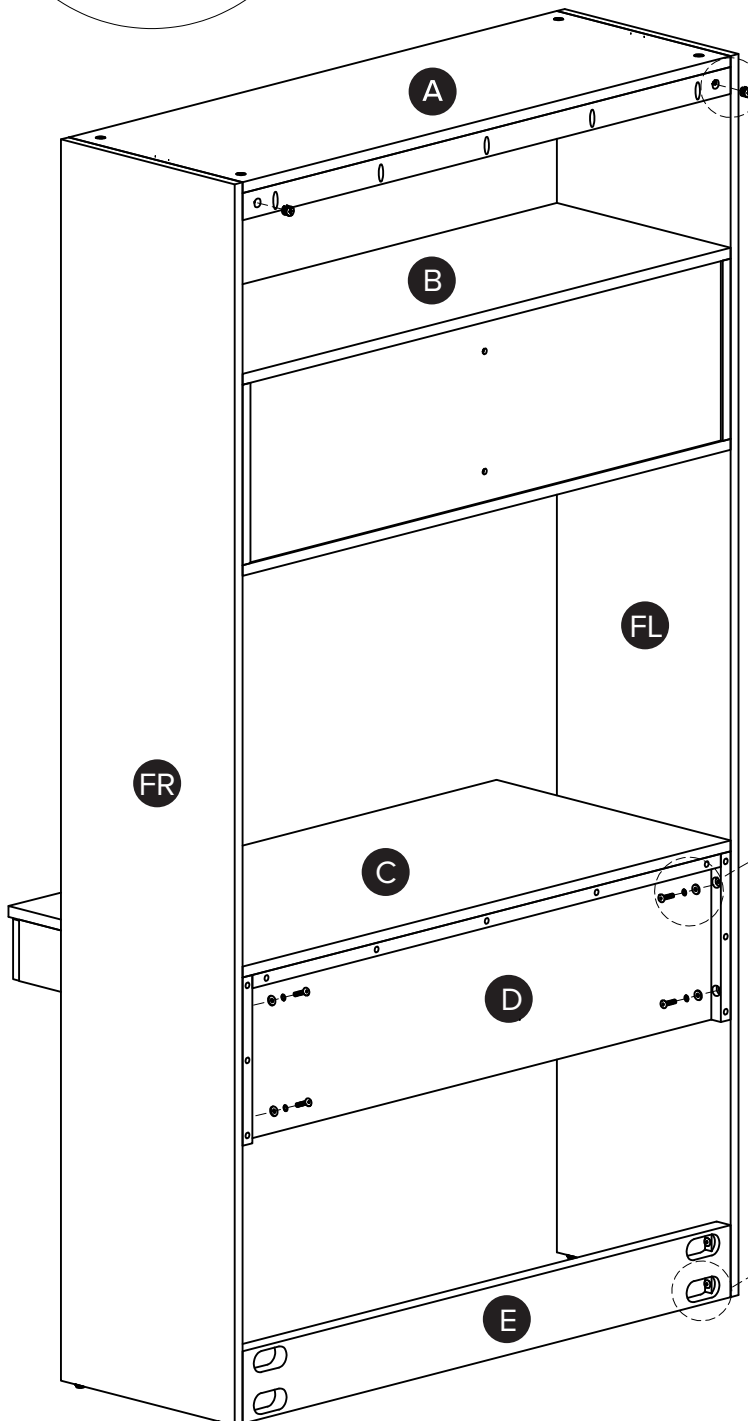
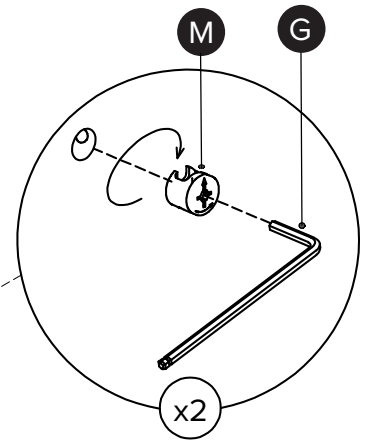
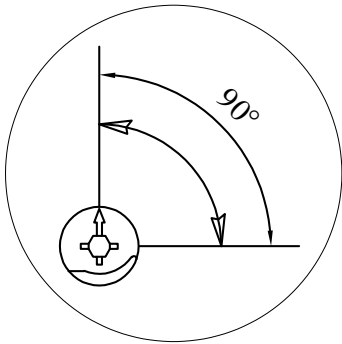

8

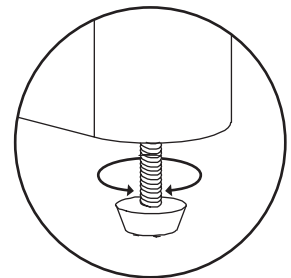
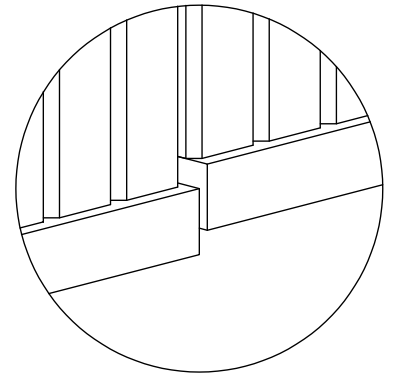
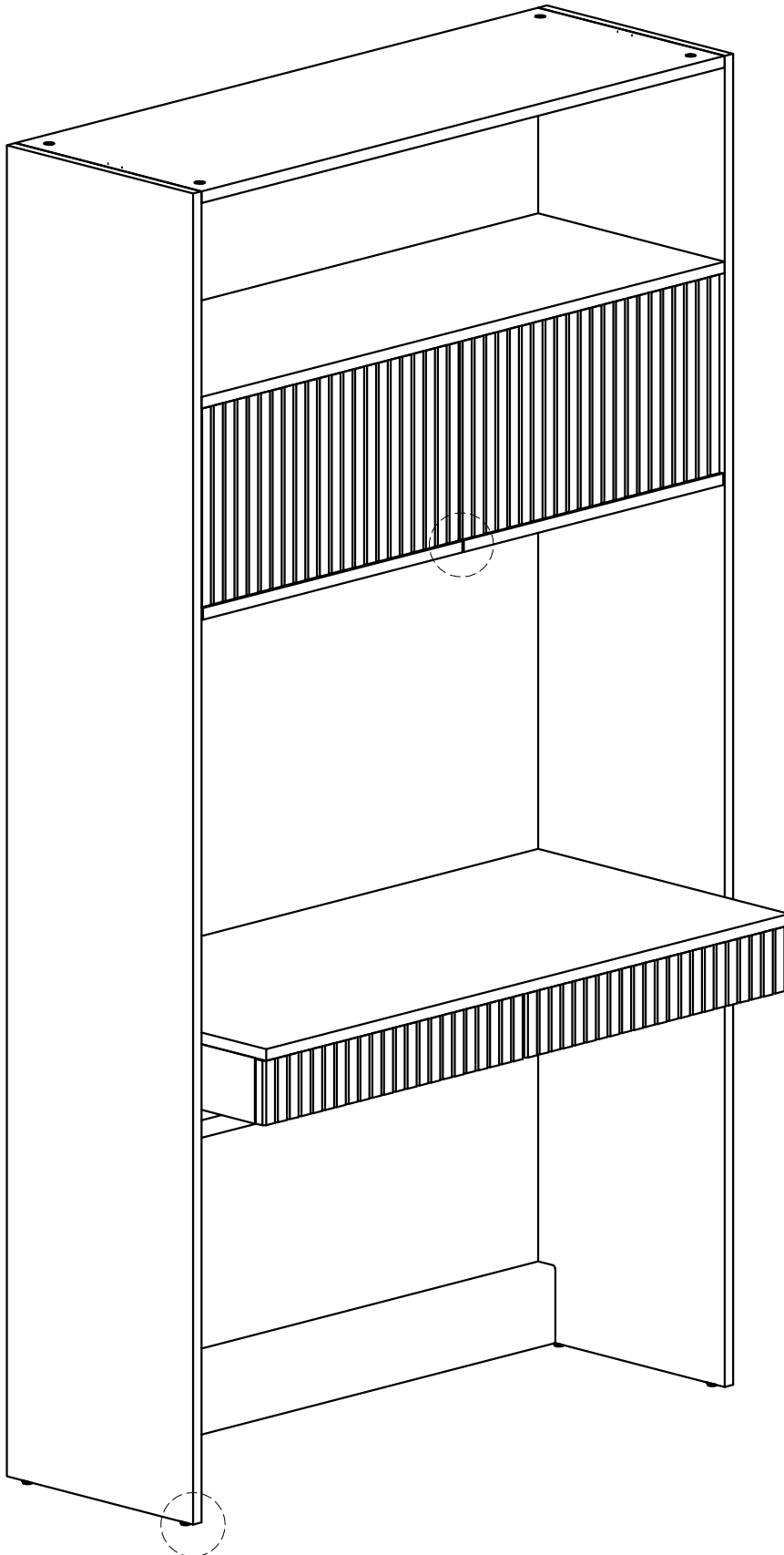

! Adjust levelers as needed.

## DOOR ADJUSTMENT INSTRUCTIONS

**!** During shipping, the doors of your cabinet may have shifted slightly. This can easily be corrected by tightening a few screws. Always start by adjusting the top hinge on the affected door.

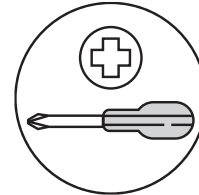

1

**!** If the door is crooked, adjust hinge(s) up or down:

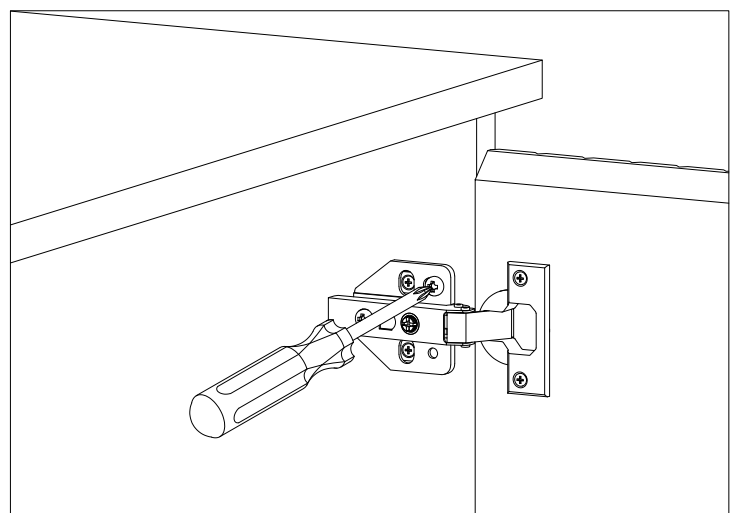
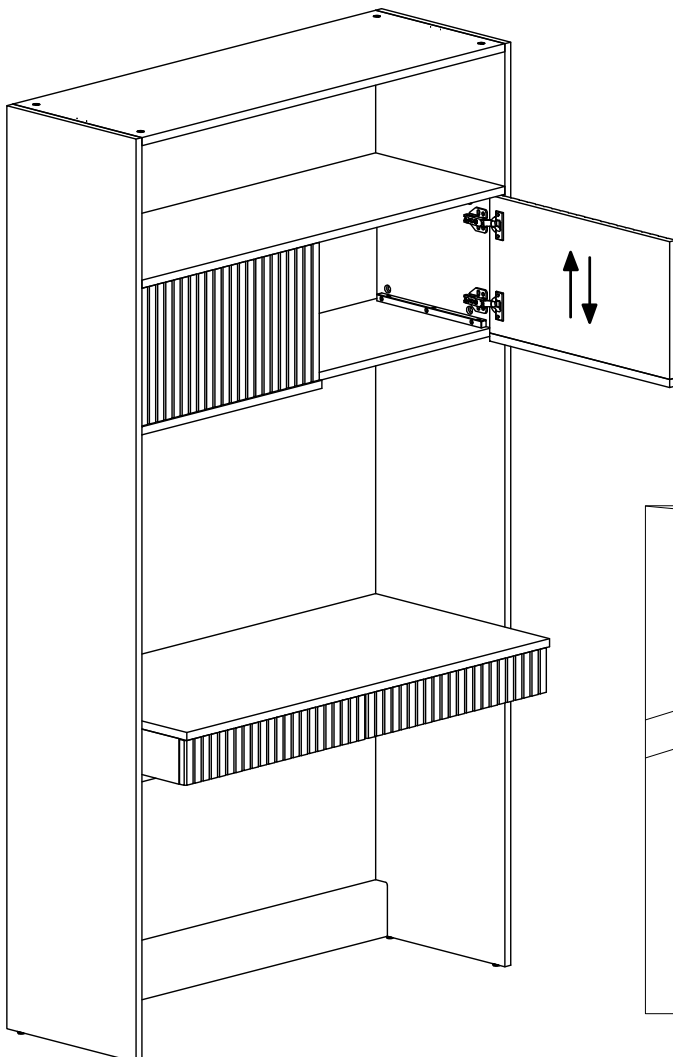

## DOOR ADJUSTMENT INSTRUCTIONS

**!** During shipping, the doors of your cabinet may have shifted slightly. This can easily be corrected by tightening a few screws. Always start by adjusting the top hinge on the affected door.

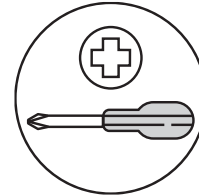

**2**

**!** If the door needs adjustment side to side:

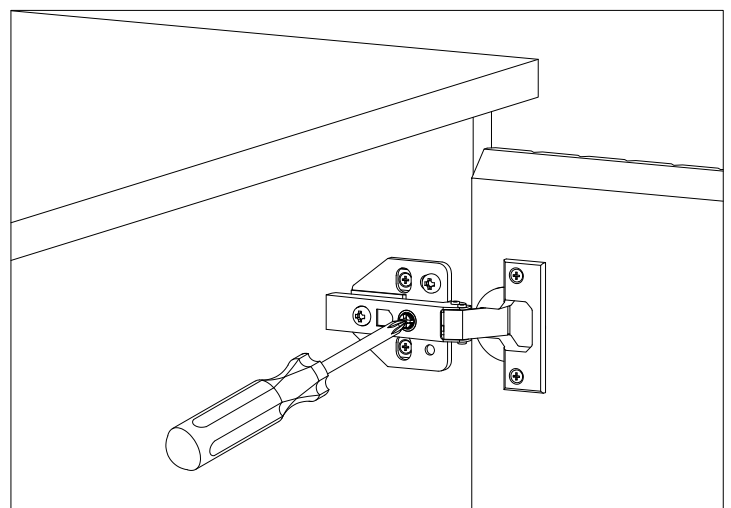
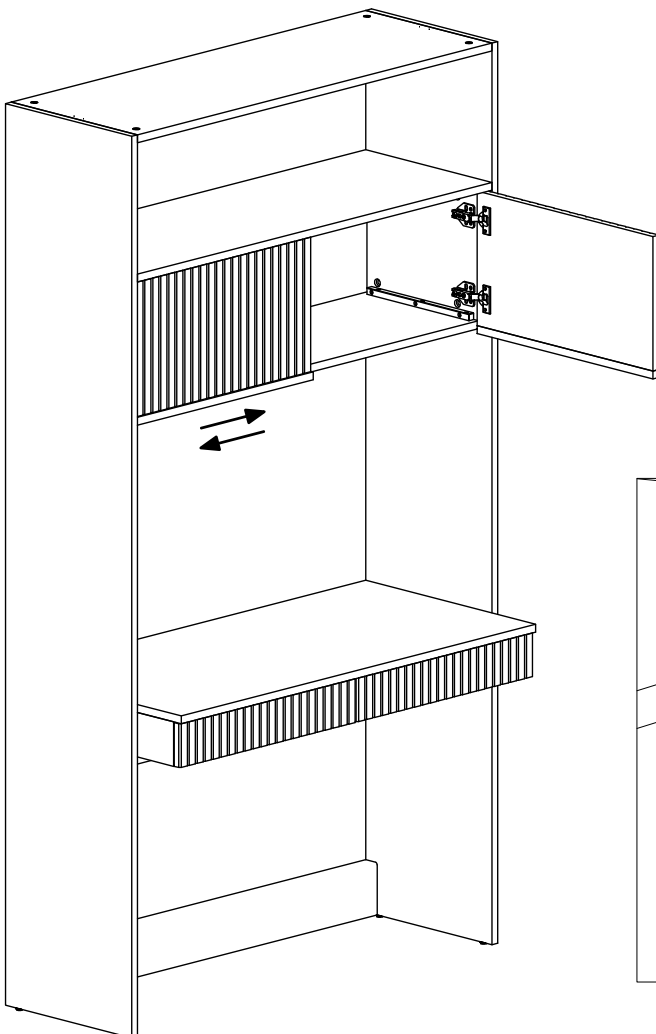

## DOOR ADJUSTMENT INSTRUCTIONS



During shipping, the doors of your cabinet may have shifted slightly. This can easily be corrected by tightening a few screws. Always start by adjusting the top hinge on the affected door.

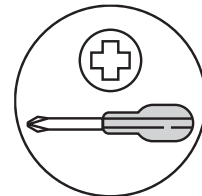

3



If the door needs adjustment forward or backward:

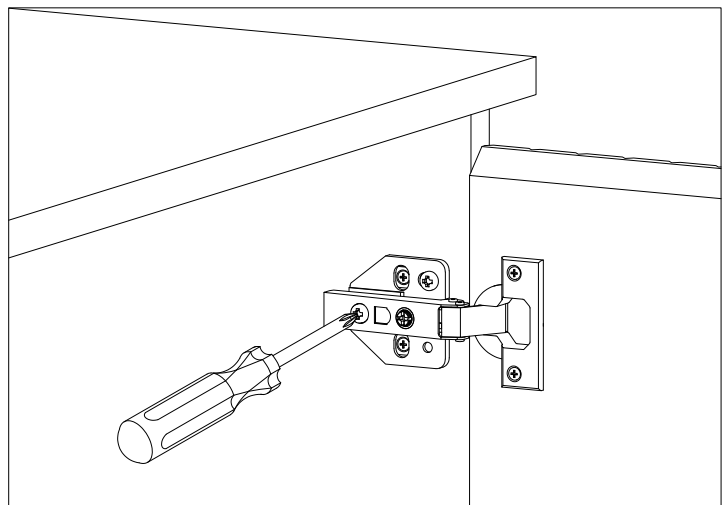
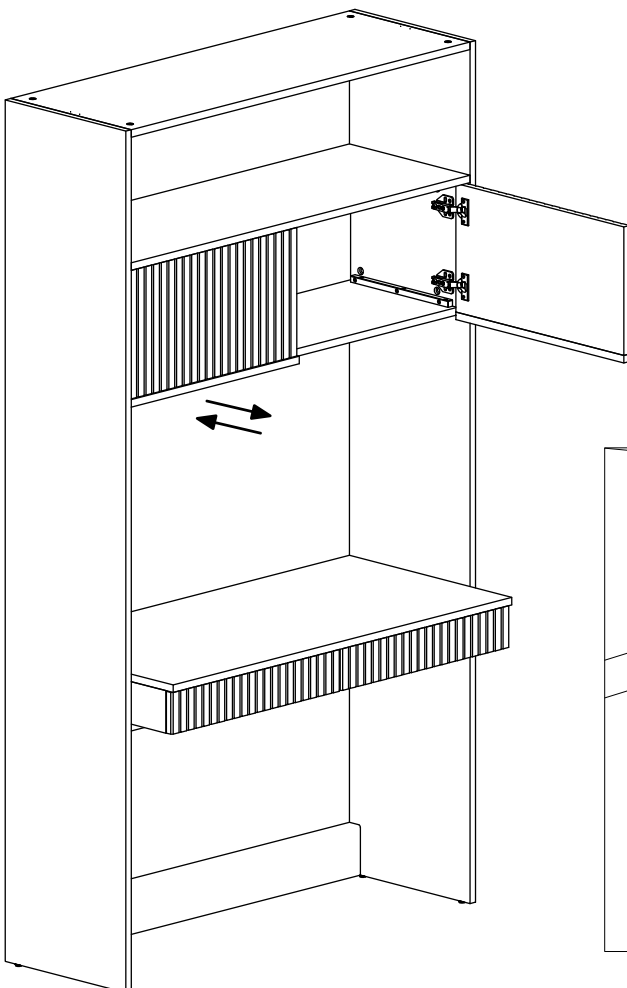



## ANTI-TIP RESTRAINT INSTALLATION

### **WARNING!**

Serious or fatal crushing injuries can occur from furniture tip-over. To help prevent tip-over:

- Install tip-over restraint provided.
- Do not set heavy objects on top of this product, unless the product is specifically designed to accommodate them.
- Never allow children to climb or hang on mirrors, shelves, consoles, or cabinets with doors and/or drawers.

Use of tip-over restraints may only reduce but not eliminate, the risk of tip-over.

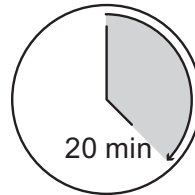

20 min

**TIME**

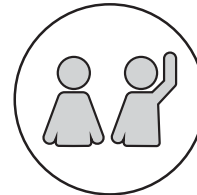

**# OF PEOPLE**

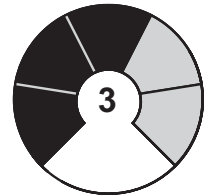

3



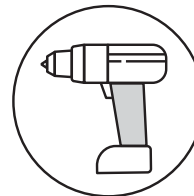

**DIFFICULTY**

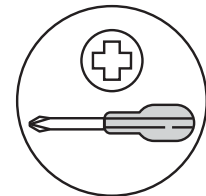

**REQUIRED TOOL**  
8MM / 5/16" DRILL BIT

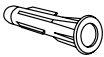
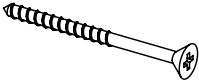

**REQUIRED TOOL**

PARTS INVENTORY CONT.		
ID	DESCRIPTION	QTY
<b>O</b>	BRACKET 	2
<b>P</b>	M4 × 15MM SCREW 	2
<b>Q</b>	M8 × 51MM PLUG 	2
<b>R</b>	M6 × 70MM SCREW 	2
<b>S</b>	WASHER 	2



Hardware (Q/R) to attach brackets to wall is designed for drywall. To attach this unit to another type of wall, consult with your local hardware store.

1

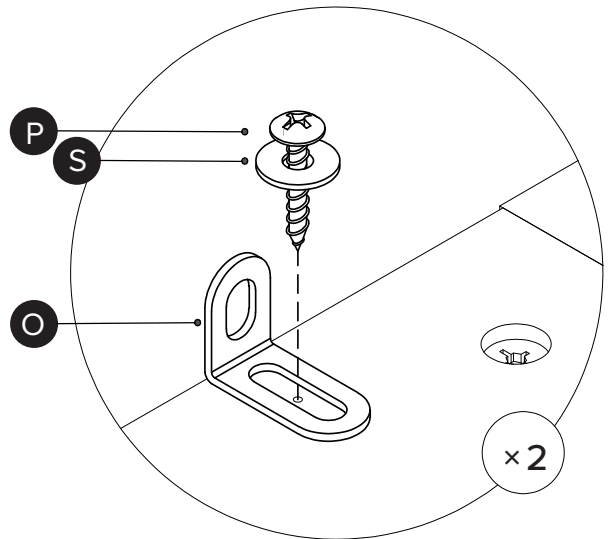
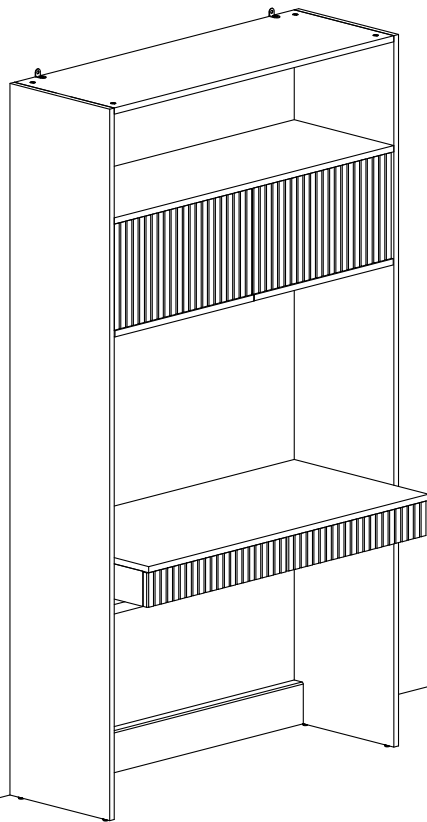

! Attach the bracket (O) into the underside of the top shelf as shown in the illustration. use screw (P) and washer (S) to attach the bracket into the pre-drilled hole underside of top shelf.

2

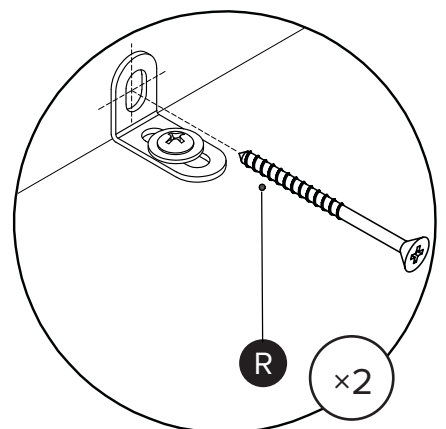
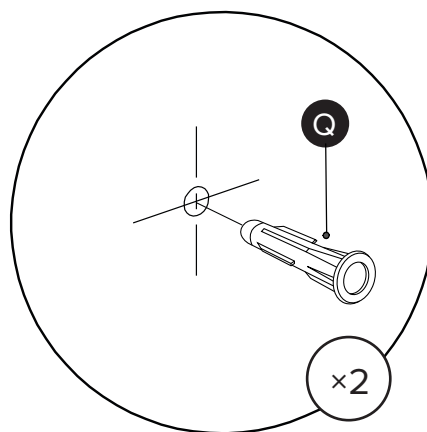
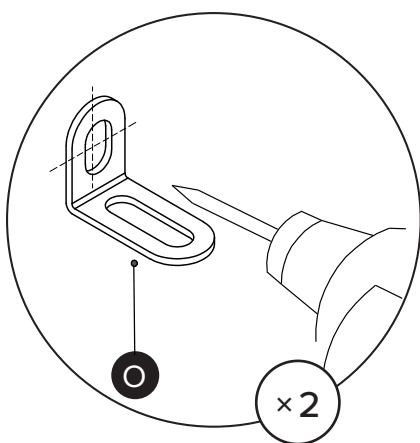

Place unit in desired location and mark on wall where holes should be drilled. Drill holes in wall using 8mm / 5/16" drill bit.

Drill holes into drywall, and attach unit to wall with appropriate hardware.