

ARTICLE.

VERSION 1.0

Assembly Instructions



BEA

Executive Office Chair

ASSEMBLY INSTRUCTIONS

Read these instructions carefully and keep for future reference. Refer to parts inventory for guidance, and ensure you have all pieces before starting.

When assembling, place all parts on a soft, clean, and flat surface such as a carpet to prevent scratches.

If you're having difficulty, our friendly Customer Care team is always here to help. Call us at **1.888.746.3455** during business hours, email service@article.com or chat live at [article.com](https://www.article.com).

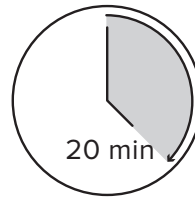

20 min

TIME

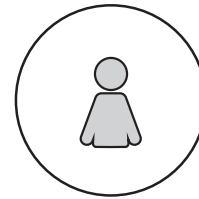



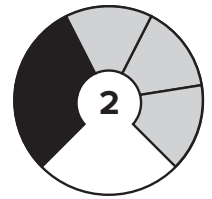



OF PEOPLE



2

DIFFICULTY

PARTS INVENTORY		
ID	DESCRIPTION	QTY
A	CASTER 	5
B	LEG BASE 	1
C	GAS LIFT 	1
D	SWIVEL PLATE 	1
E	SEAT 	1
F	BOLT (M8x30MM) 	4
G	ALLEN KEY 	1

1

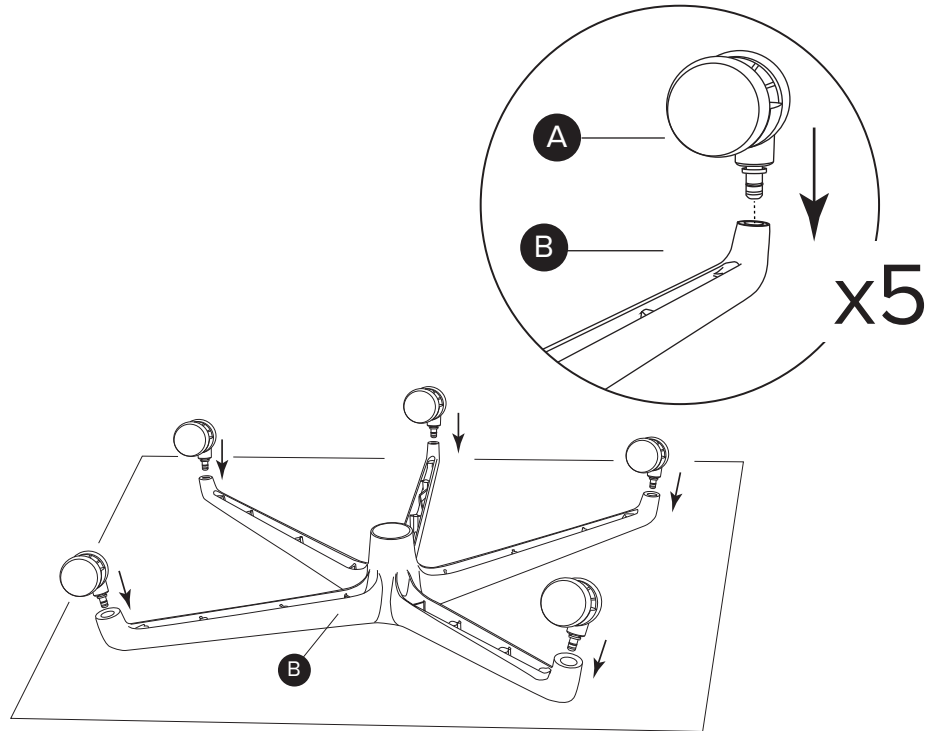

2

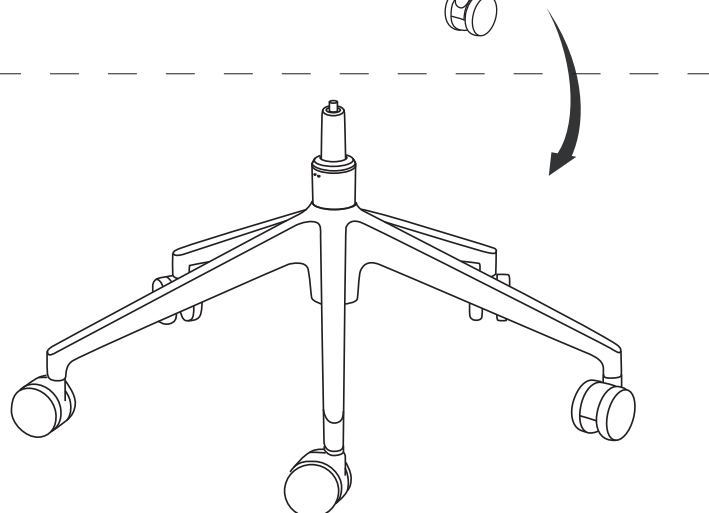
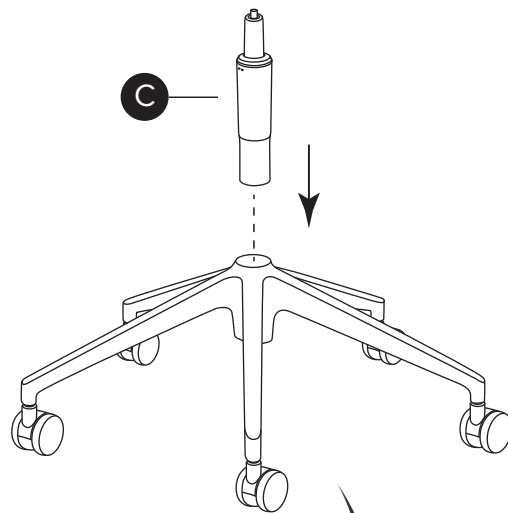
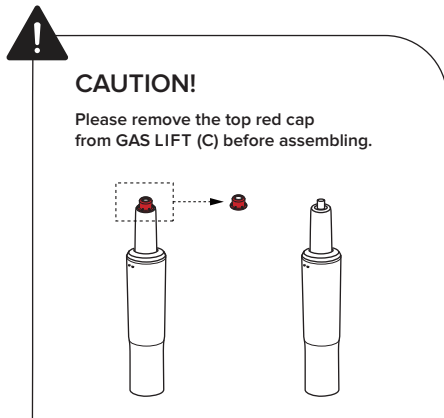

3

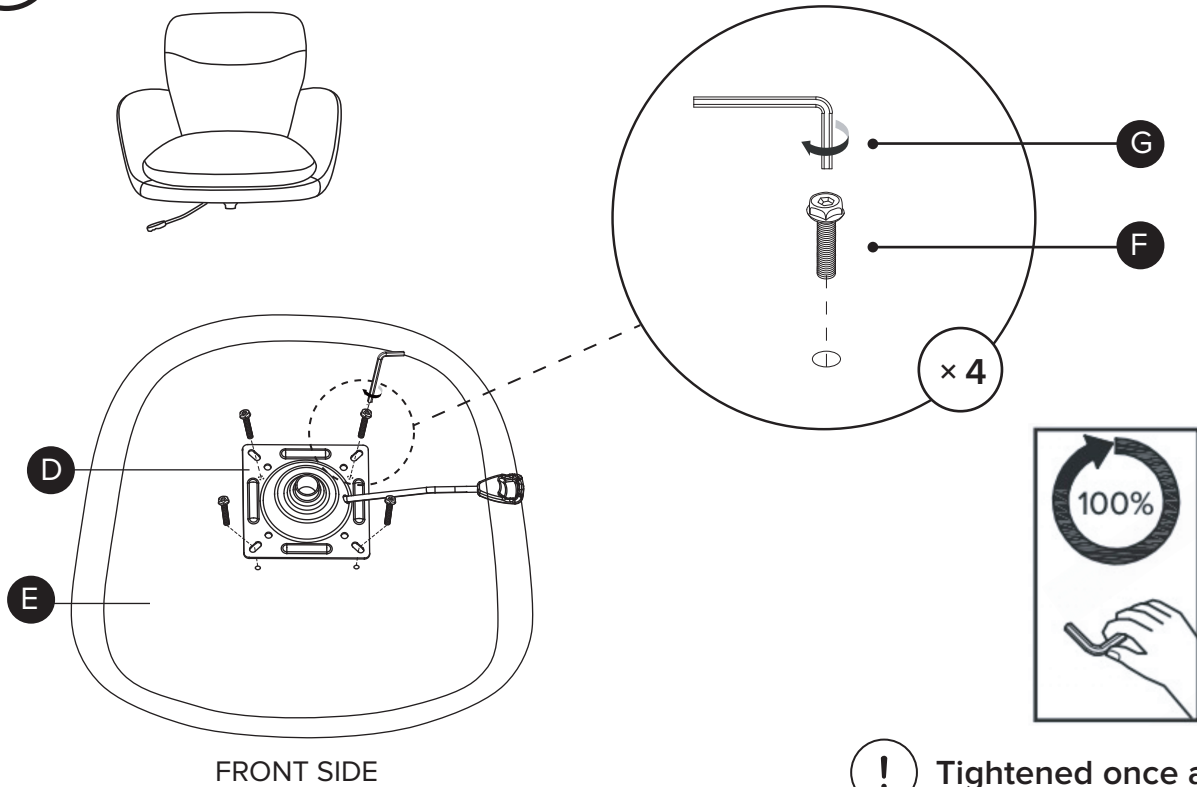

4



! Fit hole of seat assembly into gas lift of leg assembly as shown.