

ARTICLE.

VERSION 1.0

Assembly Instructions

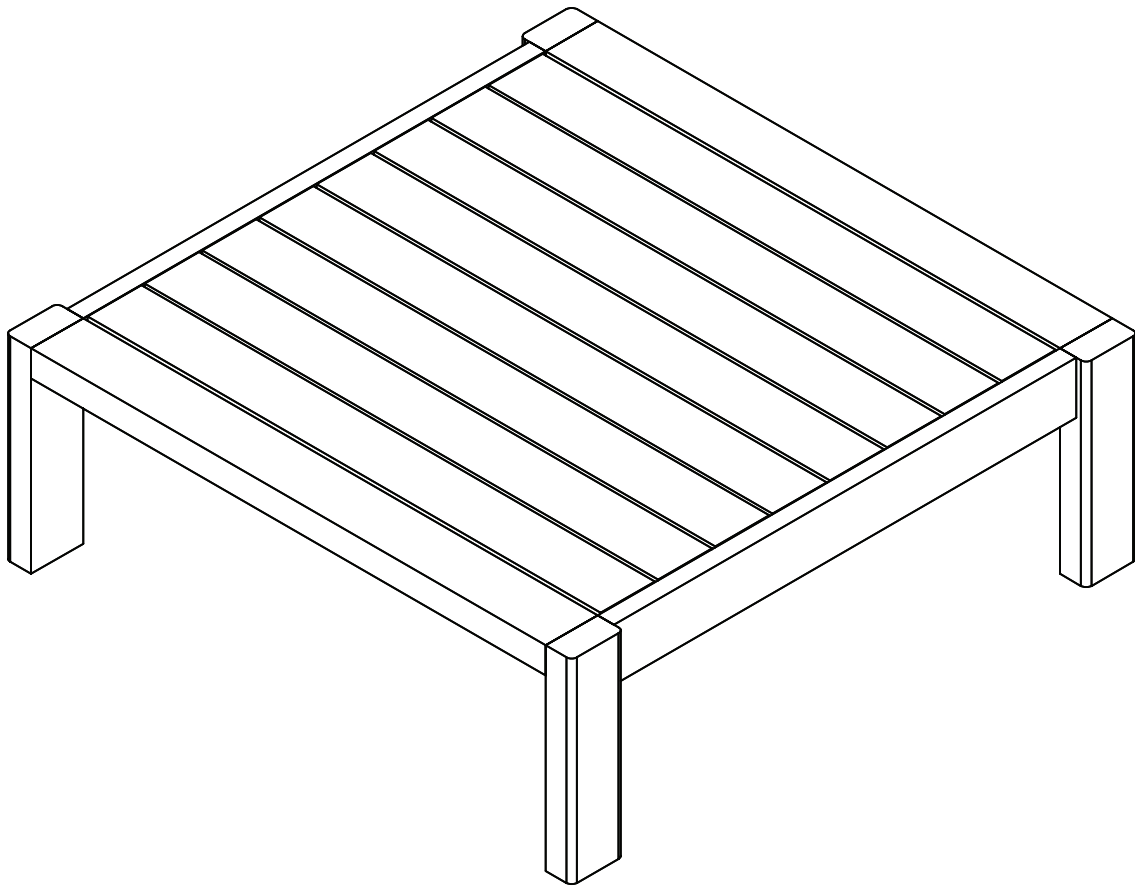

COVE COFFEE TABLE

ASSEMBLY INSTRUCTIONS

Read these instructions carefully and keep for future reference. Refer to parts inventory for guidance, and ensure you have all pieces before starting.

When assembling, place all parts on a soft, clean, and flat surface such as a carpet to prevent scratches.

If you're having difficulty, our friendly Customer Care team is always here to help. Call us at 1.888.746.3455 during business hours, email service@article.com or chat live at article.com.

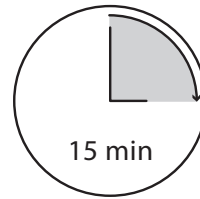

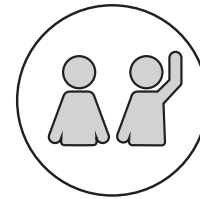

TIME



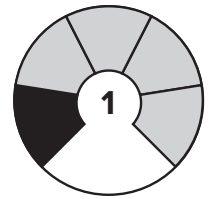



2 PEOPLE



LEVEL

PARTS INVENTORY		
ID	DESCRIPTION	QTY
A	TABLE TOP 	1
B	LEGS 	2

HARDWARE LIST			
ID	DESCRIPTION		QTY
C	BOLT	M6x45 	12
D	LOCK WASHER	M6 	12
E	WASHER	M6 	12
F	ALLEN KEY	#4 x100 	1

1

Align assembly holes on table top (A) with inserted nuts on the legs (B). Assemble them together using bolt (C), lock washer (D), washer (E) and tighten by Allen key (F).

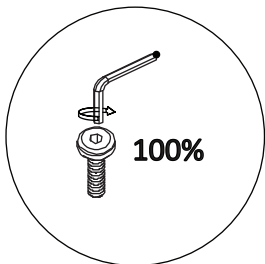
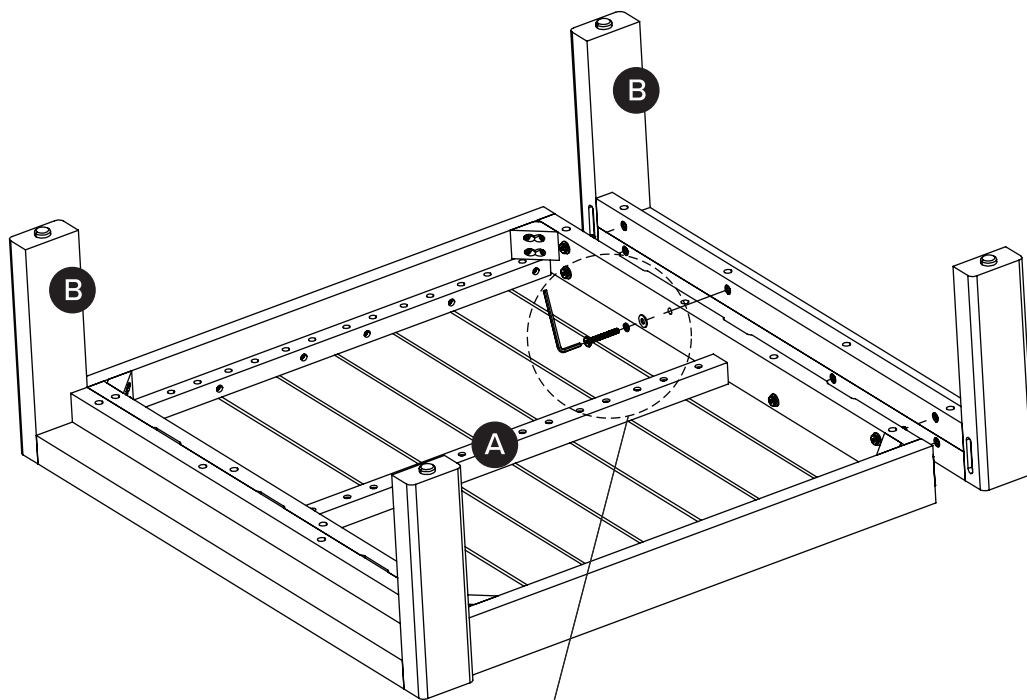

! Ensure bolts (C) and washers (D/E) are installed in the correct order to avoid damage to the table.

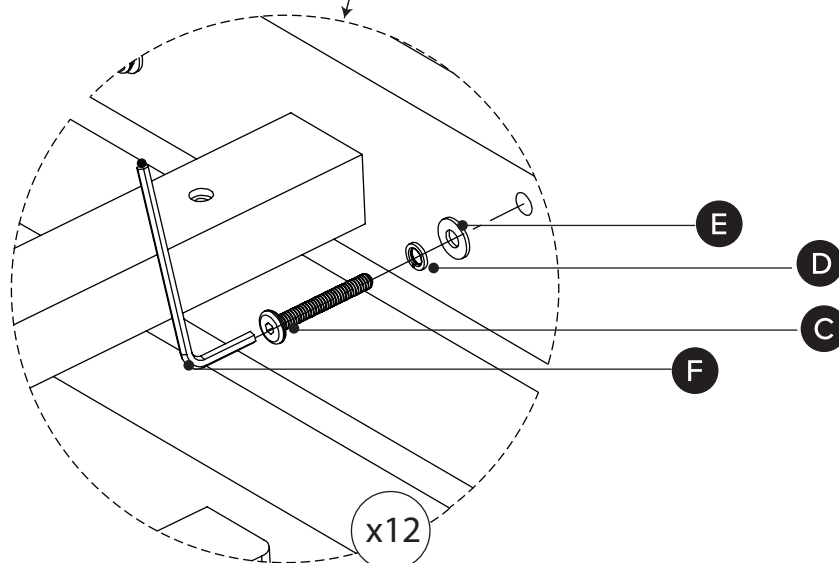

Tip: user advised to use fingers to put loose hardware together until it get tight then using the tools provided

2

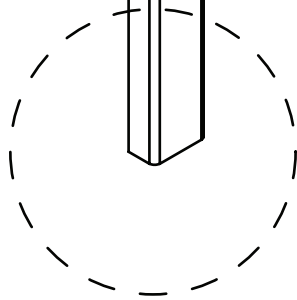
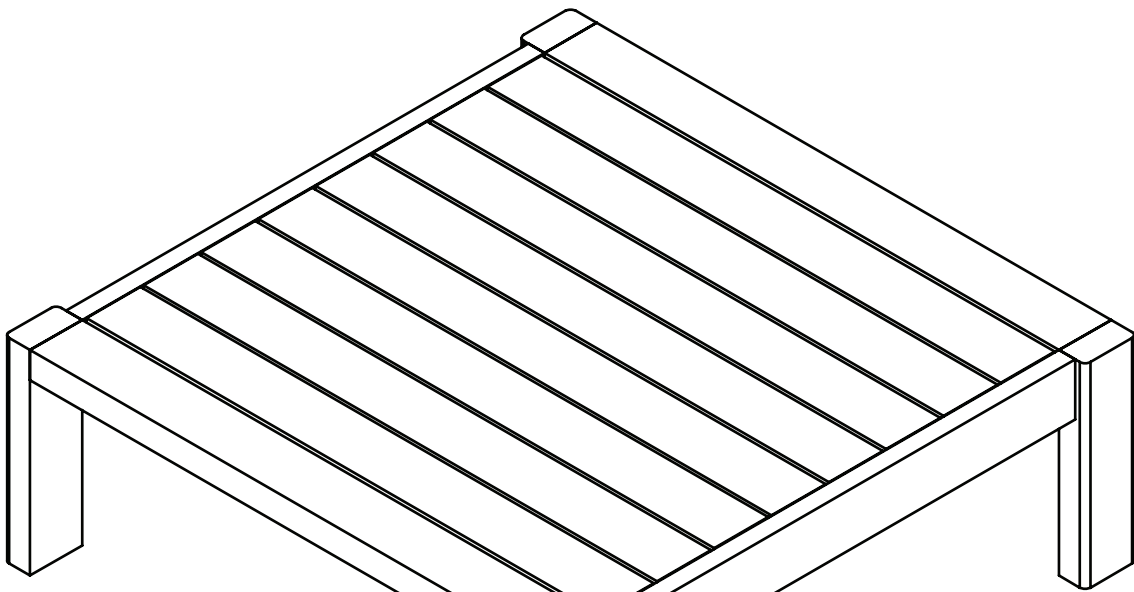

Adjust the levelers at the underneath of the legs (if need) for product stability.

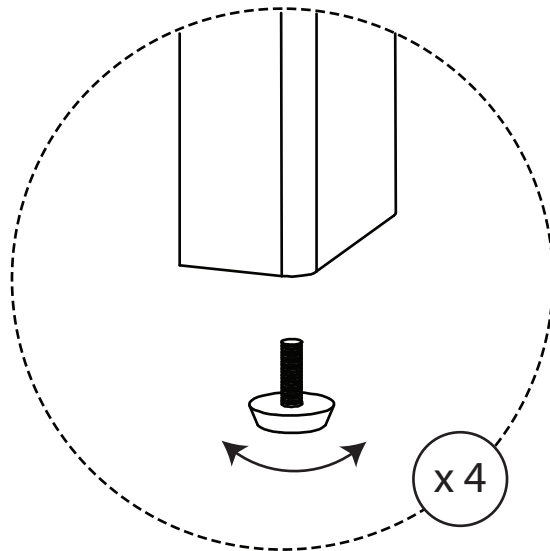

x 4