

ARTICLE.

VERSION 1.0

Assembly Instructions

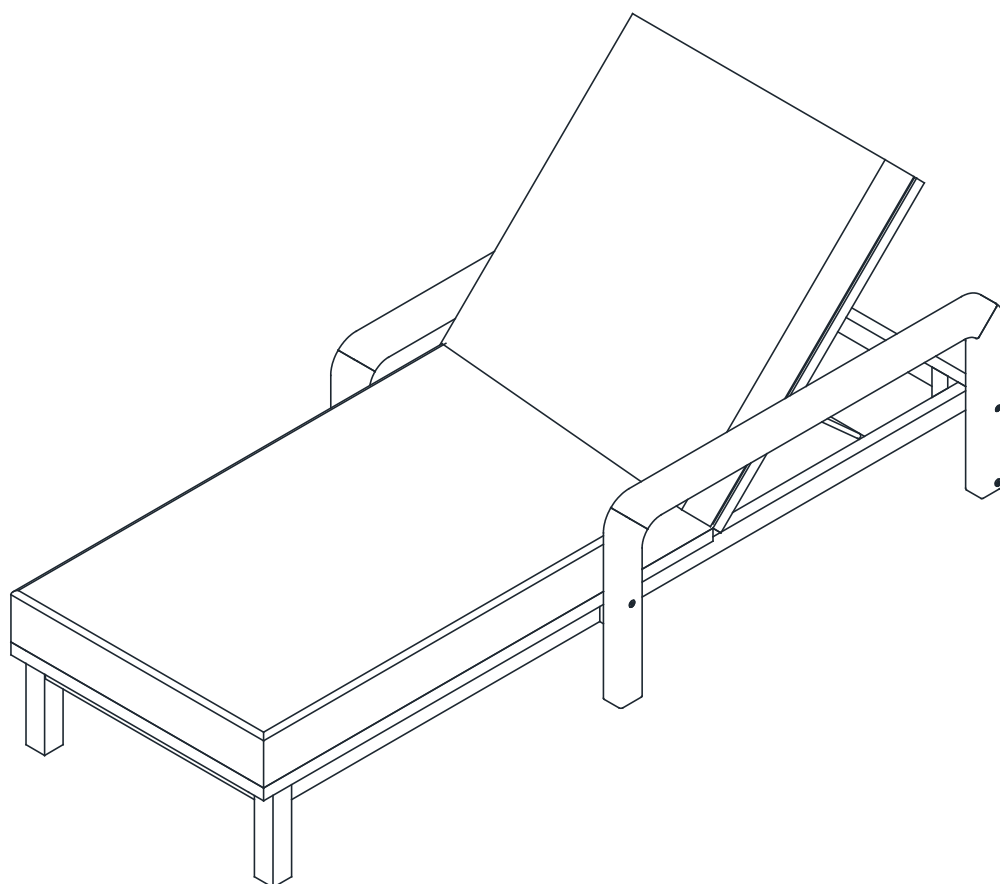

LAHOLM

CHAISE LOUNGE

ASSEMBLY INSTRUCTIONS

Read these instructions carefully and keep for future reference. Refer to parts inventory for guidance, and ensure you have all pieces before starting.

When assembling, place all parts on a soft, clean, and flat surface such as a carpet to prevent scratches.

If you're having difficulty, our friendly Customer Care team is always here to help. Call us at 1.888.746.3455 during business hours, email service@article.com or chat live at [article.com](https://www.article.com).

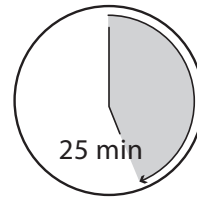

25 min



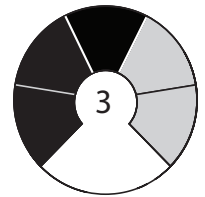

TIME

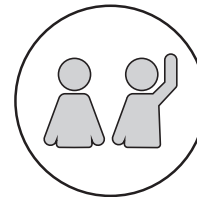





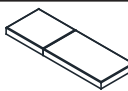

DIFFICULTY

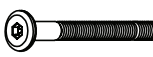

2 PEOPLE

| PARTS INVENTORY | | | |
|-----------------|-------------|---|-----|
| ID | DESCRIPTION | | QTY |
| A | LEFT LEG |  | 1 |
| B | RIGHT LEG |  | 1 |
| C | CHAISE DECK |  | 1 |
| D | FRONT LEG |  | 2 |
| E | CUSHION |  | 1 |

| TOOLS INVENTORY | | | |
|-----------------|---------------------------|---|-----|
| ID | DESCRIPTION | | QTY |
| F | ALLEN KEY |  | 1 |
| H1 | BOLT GALVANIZED M6 x 70MM |  | 1 |

| HARDWARE INVENTORY | | | |
|--------------------|------------------|---|-----|
| ID | DESCRIPTION | | QTY |
| G | BOLT M6 x 60MM |  | 2 |
| H | BOLT M6 x 70MM |  | 2 |
| I | BOLT M6 x 90MM |  | 2 |
| J | BOLT M8 x 60MM |  | 2 |
| K | NUTT |  | 2 |
| L | WASHER M8x25x2MM |  | 2 |

1

Assemble Left Side Legs.

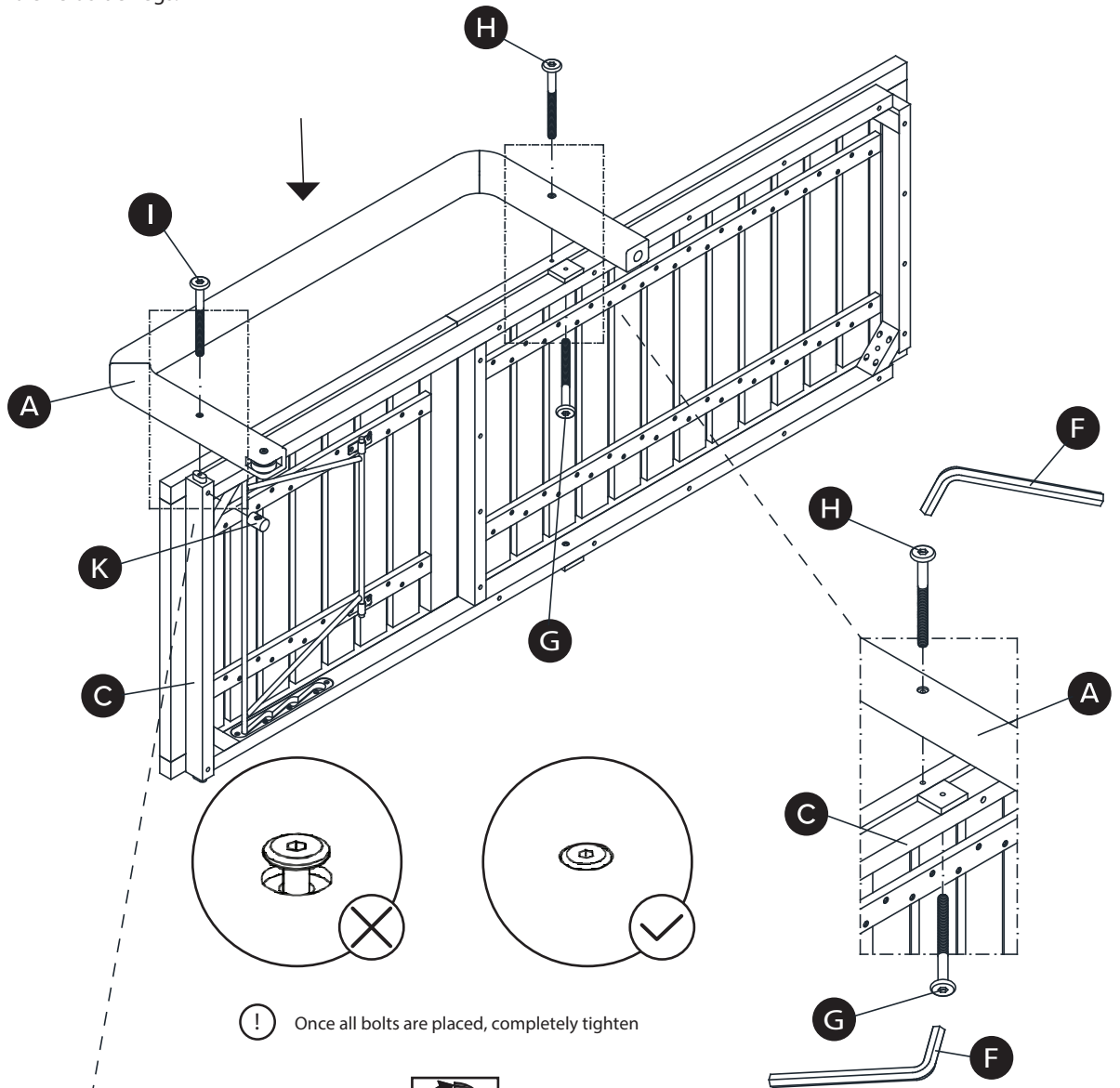

! Once all bolts are placed, completely tighten

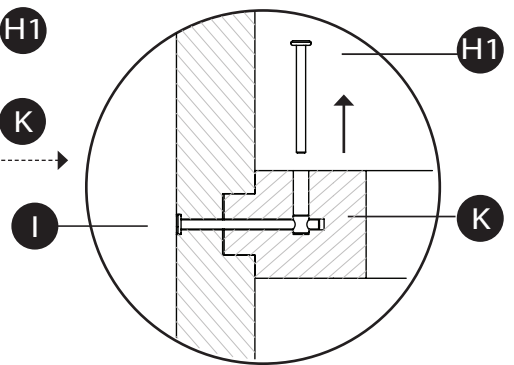
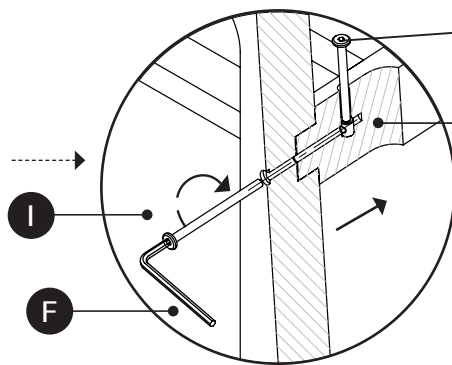
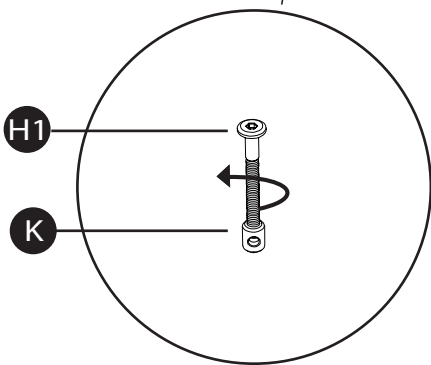

! Note: use bolt (H1) as a tool to insert temporarily and hold nut (K) to holes underneath the seat, while connecting bolt (I) to nut (K).

Nut (K) has to turn toward the right direction to connect with bolt (I).

Remove bolt (H1) after nut (K) is completely attached to bolt (I).

2

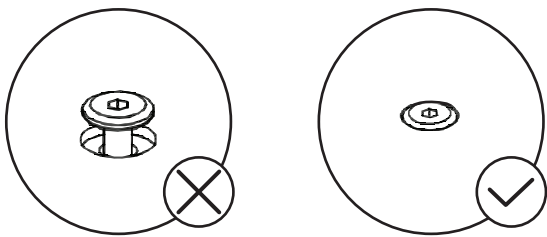
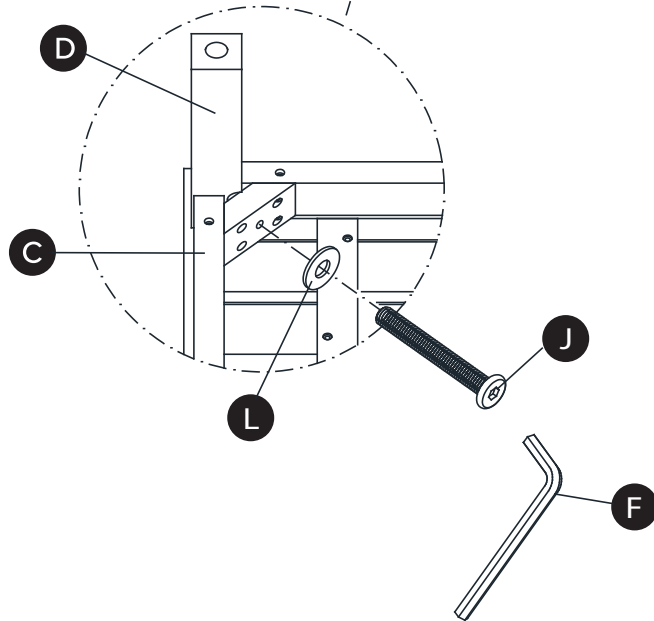
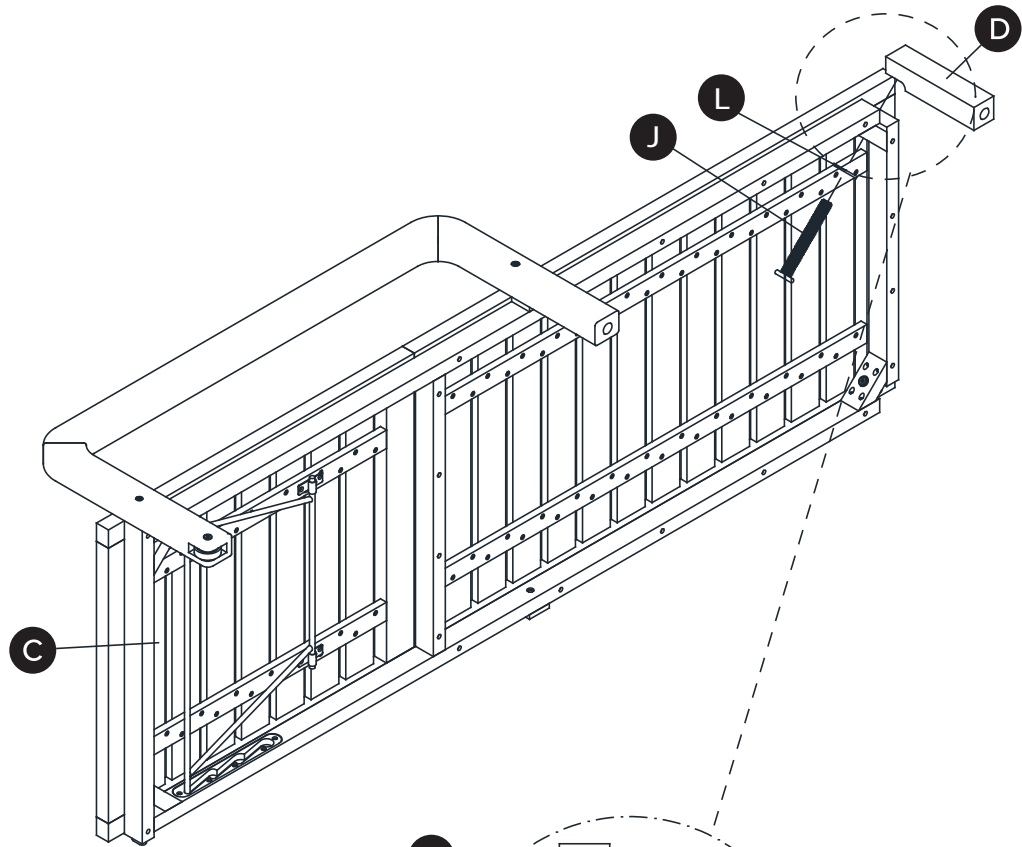

! Once all bolts are placed, completely tighten



3

Assemble Right Side Legs.

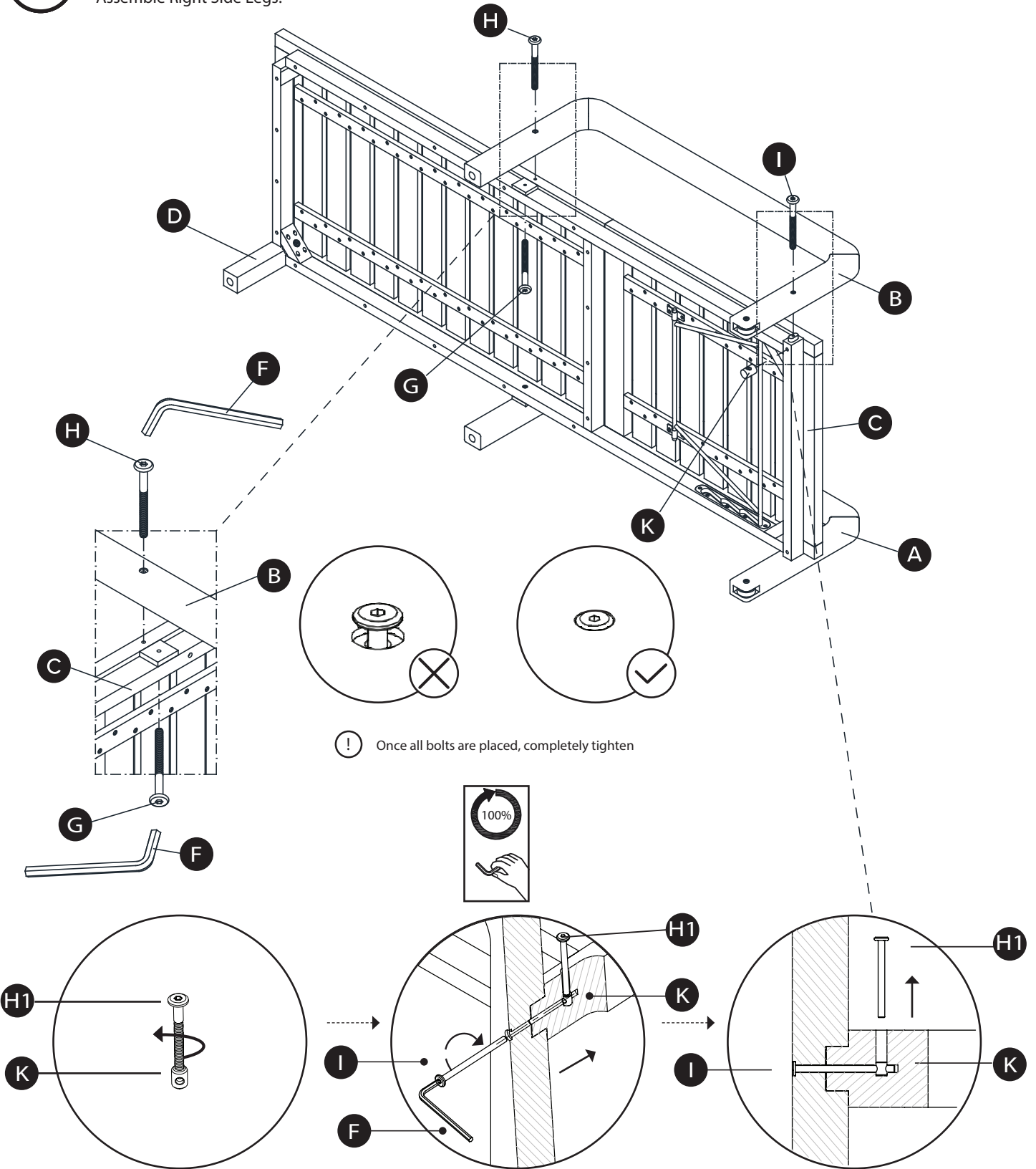

! Once all bolts are placed, completely tighten

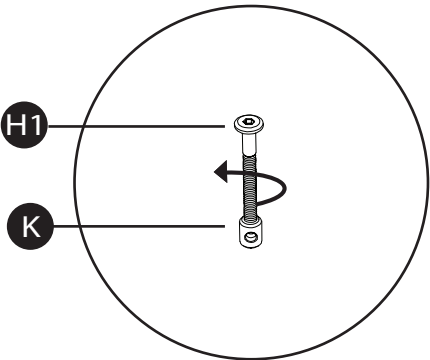

! Note: use bolt (H1) as a tool to insert temporarily and hold nut (K) to holes underneath the seat, while connecting bolt (I) to nut (K).

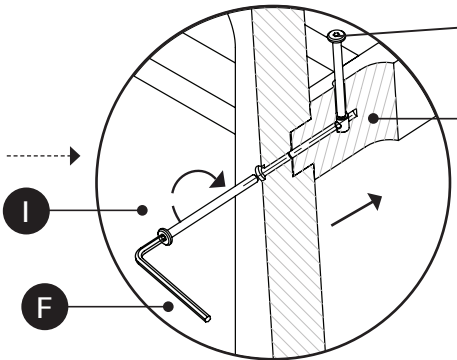

Nut (K) has to turn toward the right direction to connect with bolt (I).

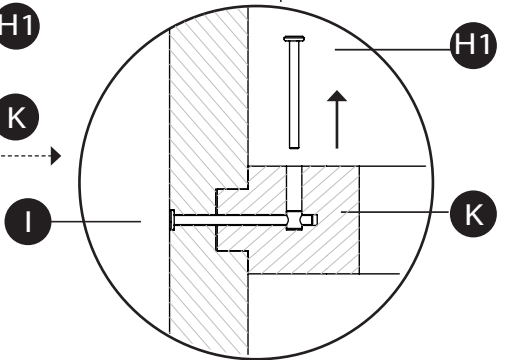

Remove bolt (H1) after nut (K) is completely attached to bolt (I).

4

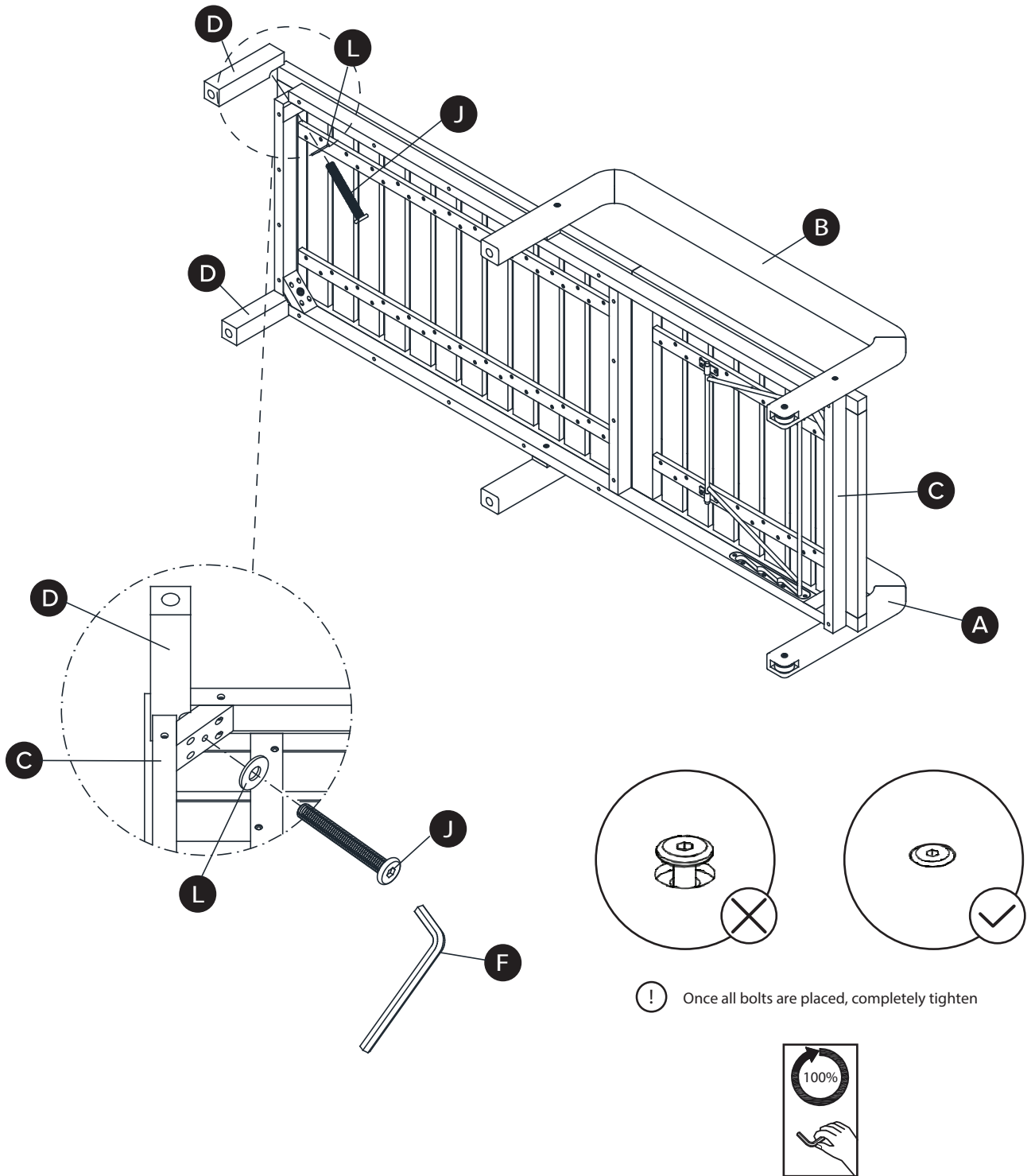

5

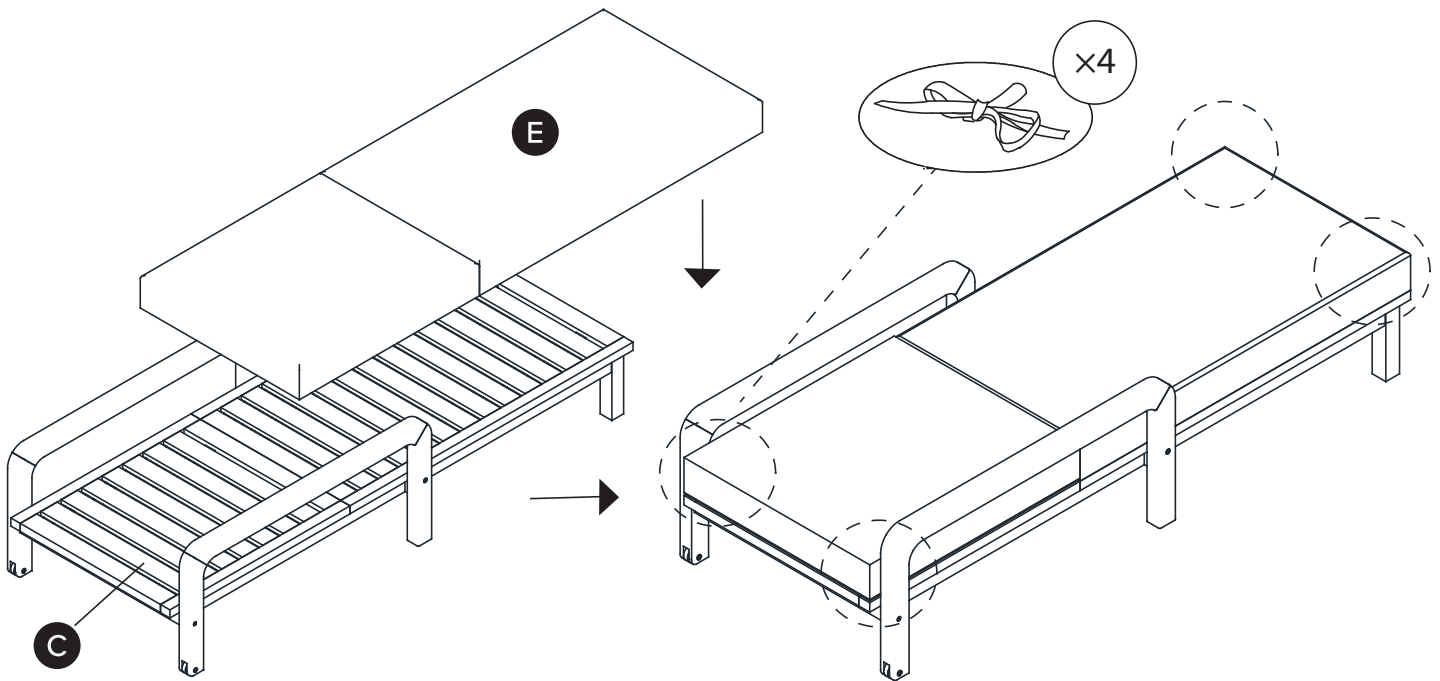

Tight cushion (E) ropes directly to the slat support bar underneath the Chaise Deck (C)

6

Turn the Chaise Lounge upright and adjust the levelers at the bottom of the legs (if needed) to balance the Chaise Lounge.

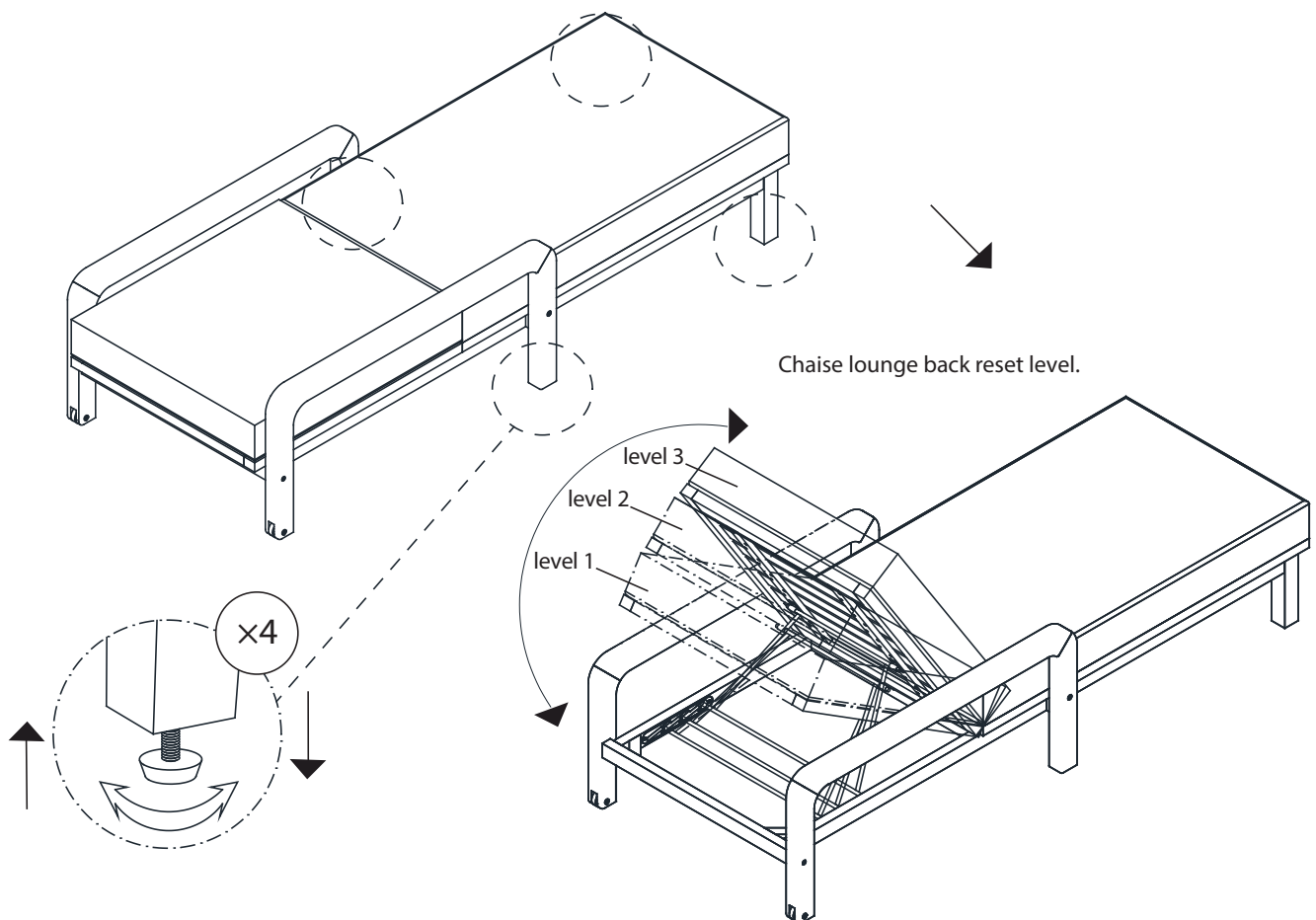

Lift up or drop down the back rest as your desisted