

ARTICLE.

VERSION 1.0

Assembly Instructions

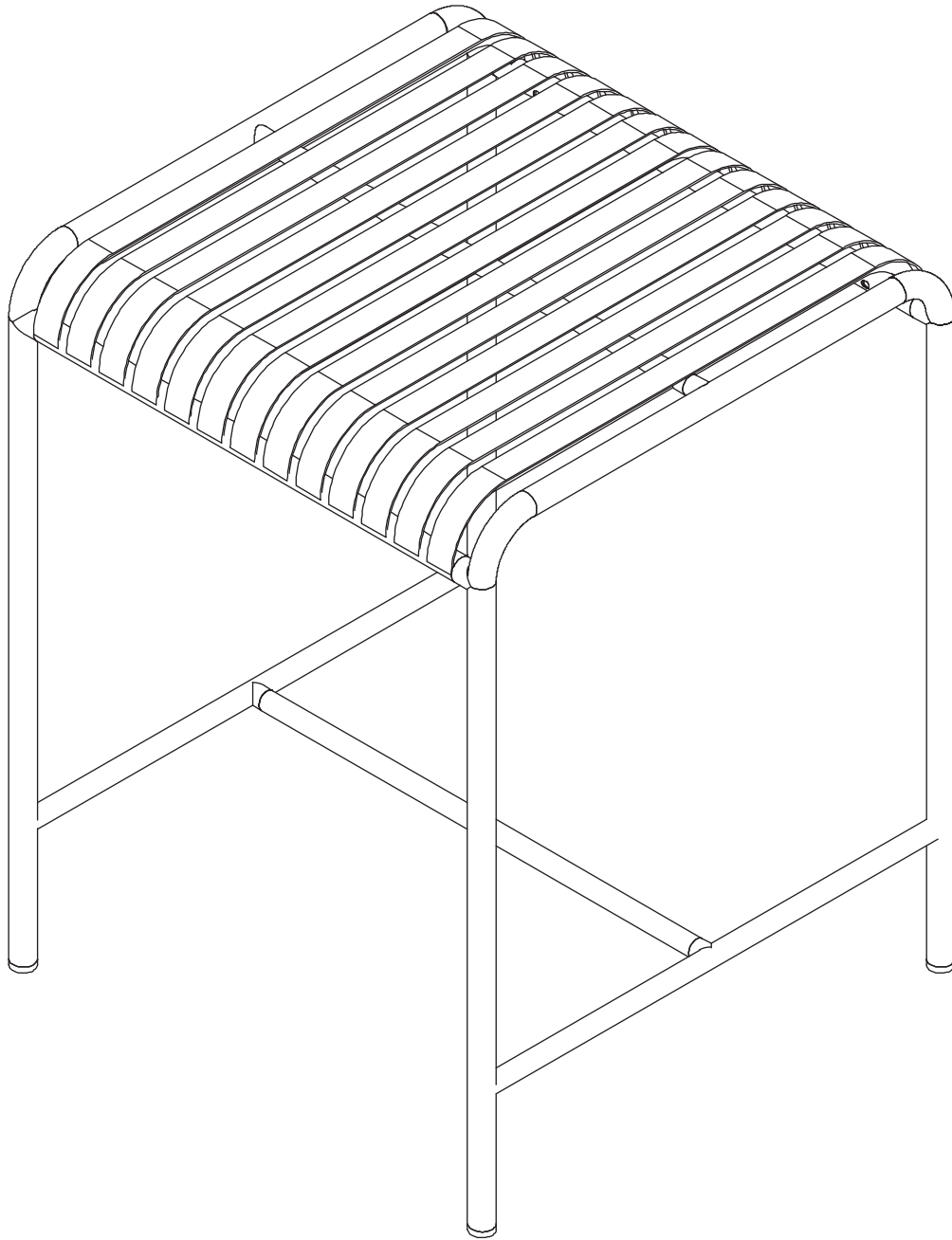

SAREK BAR TABLE

ASSEMBLY INSTRUCTIONS

Read these instructions carefully and keep for future reference. Refer to parts inventory for guidance, and ensure you have all pieces before starting.

When assembling, place all parts on a soft, clean, and flat surface such as a carpet to prevent scratches.

If you're having difficulty, our friendly Customer Care team is always here to help. Call us at 1.888.746.3455 during business hours, email service@article.com or chat live at [article.com](https://www.article.com).

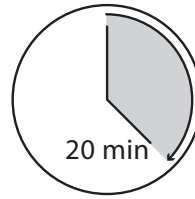

TIME

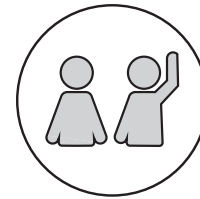



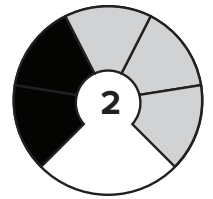

2 PEOPLE



LEVEL

PARTS INVENTORY		
ID	DESCRIPTION	QTY
A	TABLE TOP	1
B	LEG FRAME	2
C	STRETCHER	1

HARDWARE LIST				
ID	DESCRIPTION			QTY
D	BOLT	M6x15		12
E	LOCK WASHER	M6		12
F	WASHER	M6		12
G	ALLEN KEY	#4 x 100		1

1

Align assembly holes on table top (A) with inserted nuts on the leg (B) first. Align the assembly holes on stretcher (C) with insert nuts on leg (B)

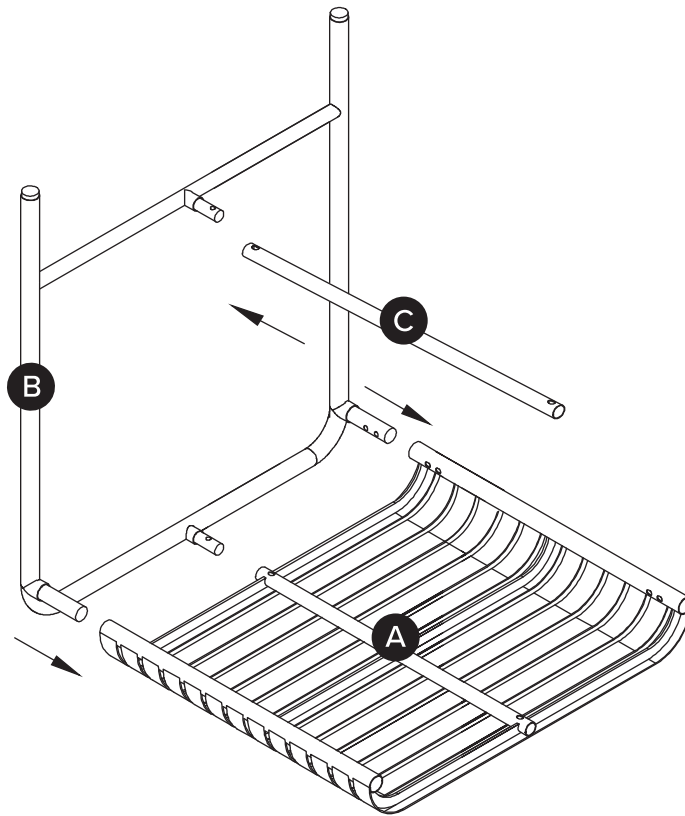

2

Please repeat the same steps for the other leg frame.

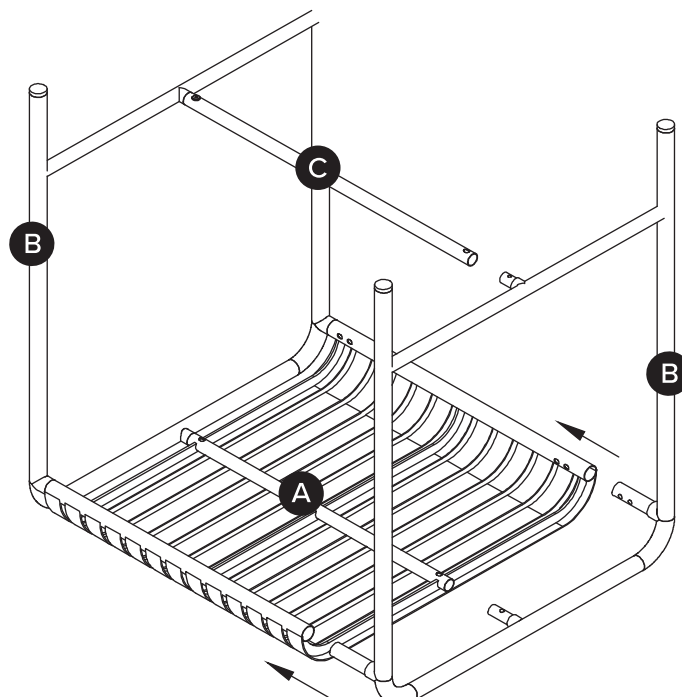

3

Assemble them together using bolt (D), lock washer (F), washer (E) and tighten by Allen key (G).

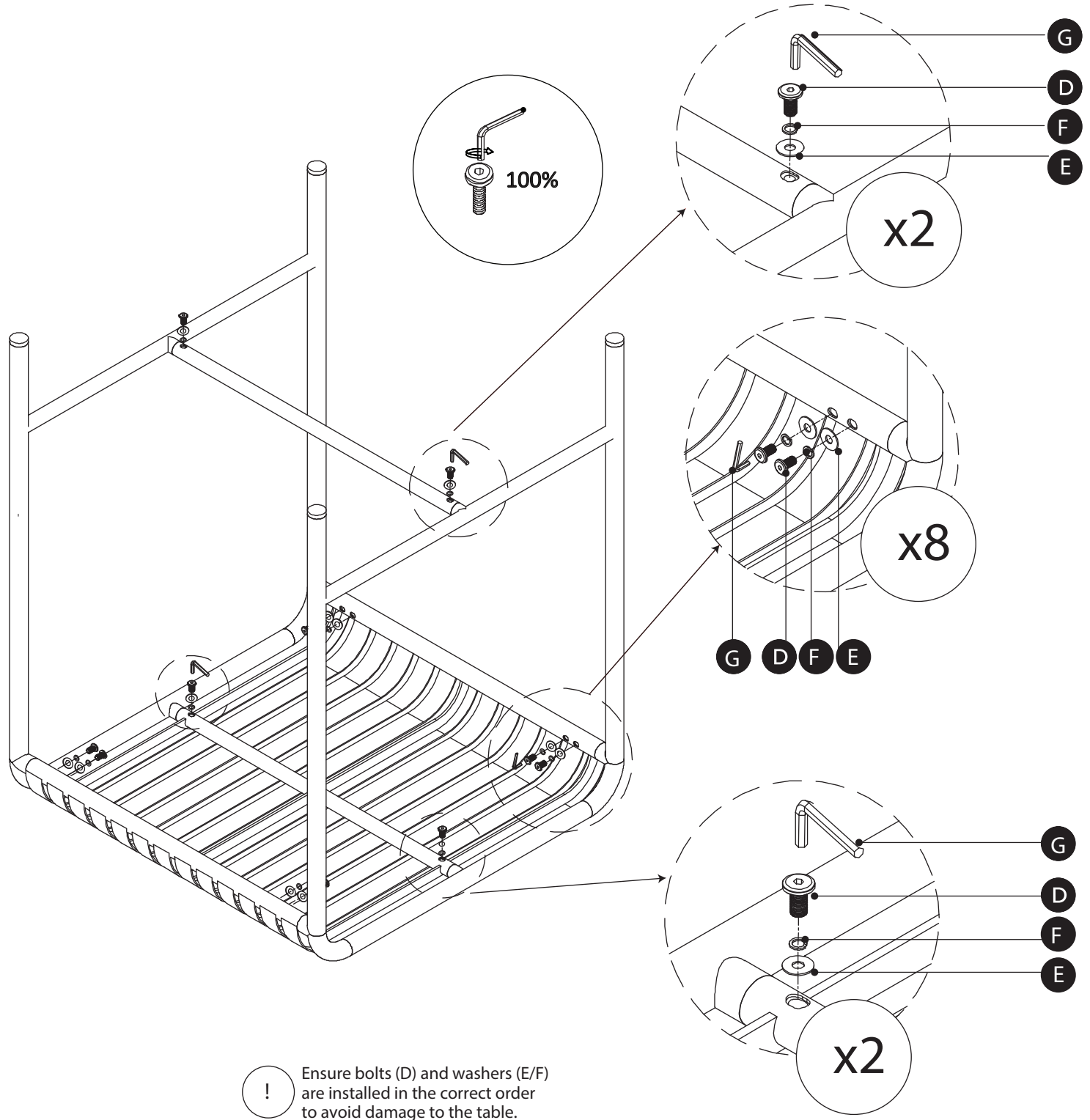

! Ensure bolts (D) and washers (E/F) are installed in the correct order to avoid damage to the table.

Tip: user advised to use fingers to put loose hardware together until it get tight then using the tools provided

4

Put the product up right.

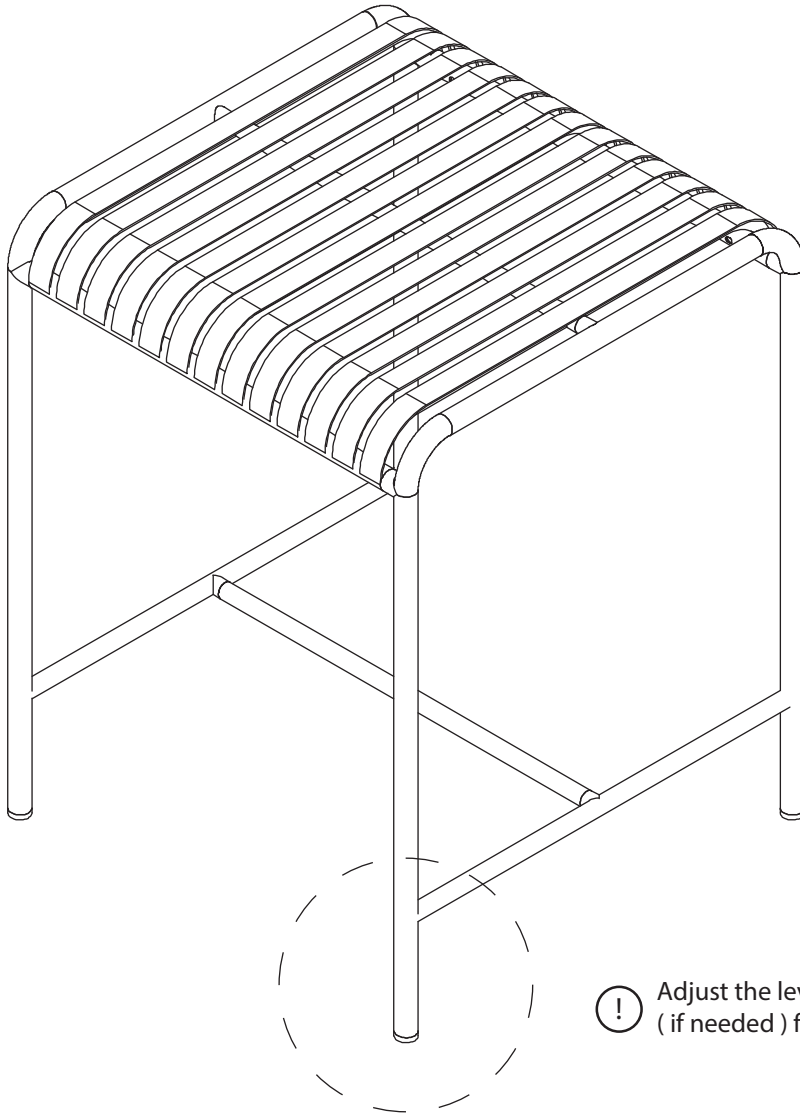

! Adjust the levelers at the underneath of the legs (if needed) for product stability

