

ARTICLE.

VERSION 1.0

Assembly Instructions

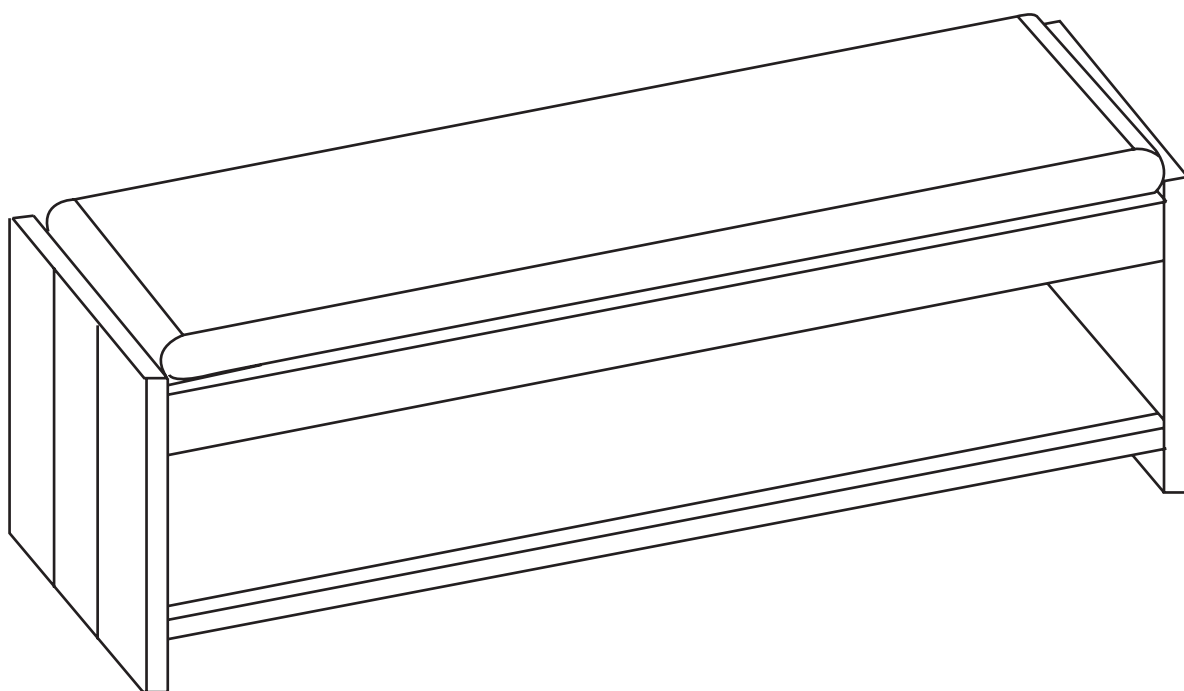

CASSIE

Bench

ASSEMBLY INSTRUCTIONS

Read these instructions carefully and keep for future reference. Refer to parts inventory for guidance, and ensure you have all pieces before starting.

When assembling, place all parts on a soft, clean, and flat surface such as a carpet to prevent scratches.

If you're having difficulty, our friendly Customer Care team is always here to help. Call us at **1.888.746.3455** during business hours, email service@article.com or chat live at [article.com](https://www.article.com).

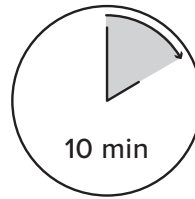

10 min

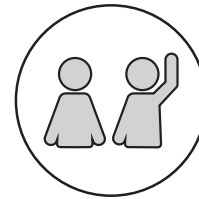

TIME



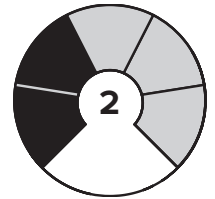



OF PEOPLE

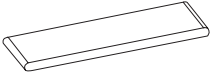

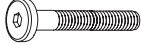
DIFFICULTY

PARTS INVENTORY		
ID	DESCRIPTION	QTY
1	LEG 	2
2	SEAT FRAME 	1
3	SHELF FRAME 	1
4	SEAT CUSHION 	1

PARTS INVENTORY		
ID	DESCRIPTION	QTY
A	WOOD DOWEL 	8
B	M8 × 50MM BOLT 	12
C	M8.5 LOCK WASHER 	12
D	M8.5 WASHER 	12
E	ALLEN KEY 	1

1

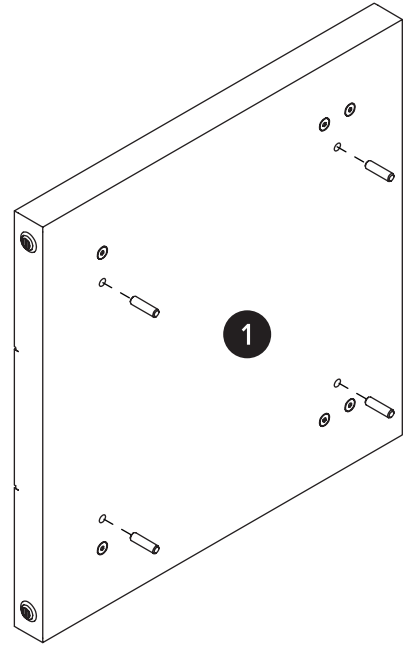
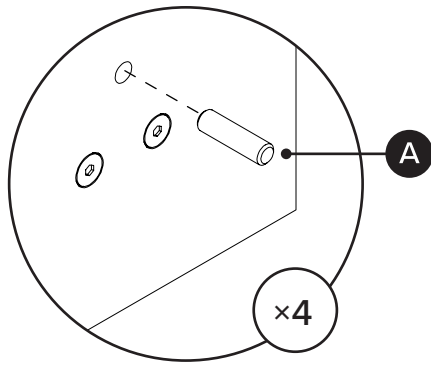

2

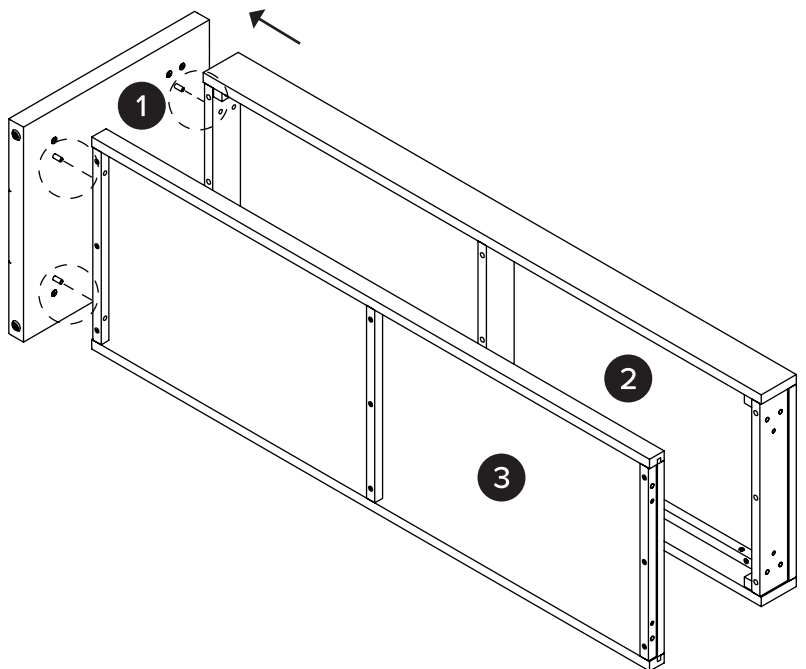
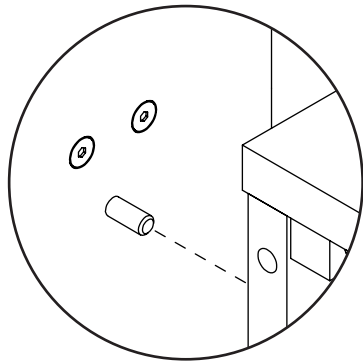

3

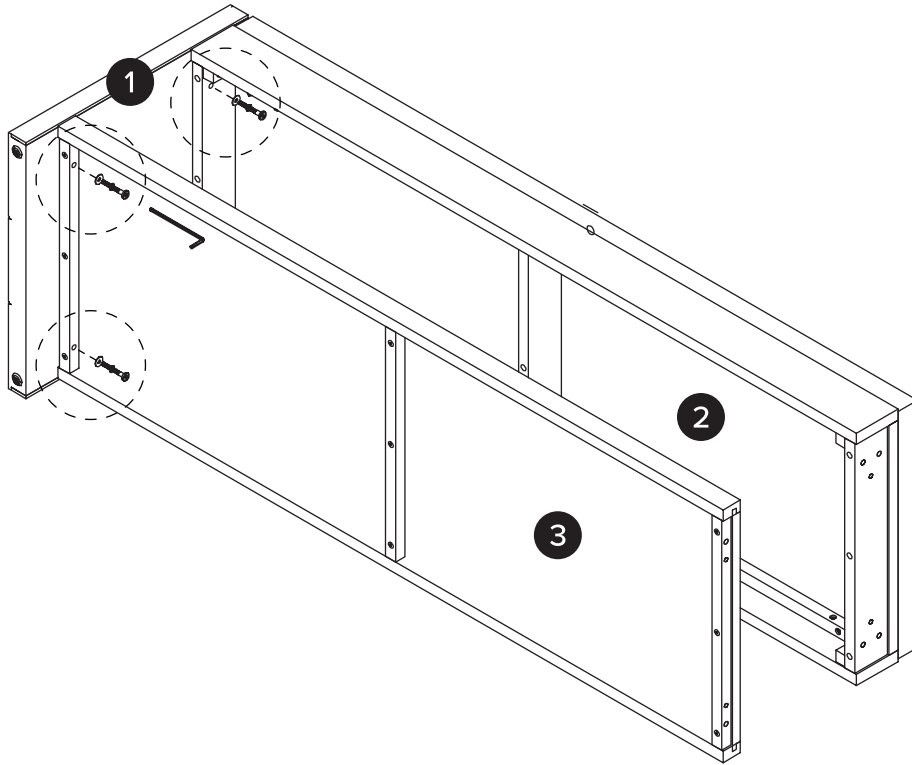

! Wrench the bolt by using the ball head of the allen key.

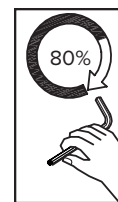
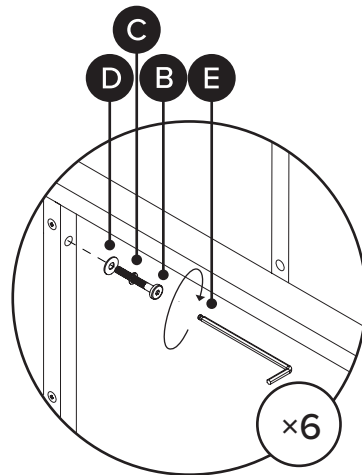
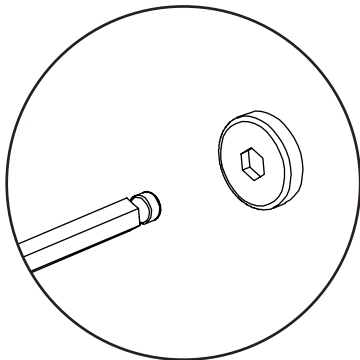

! Tighten bolts 80% only.

4

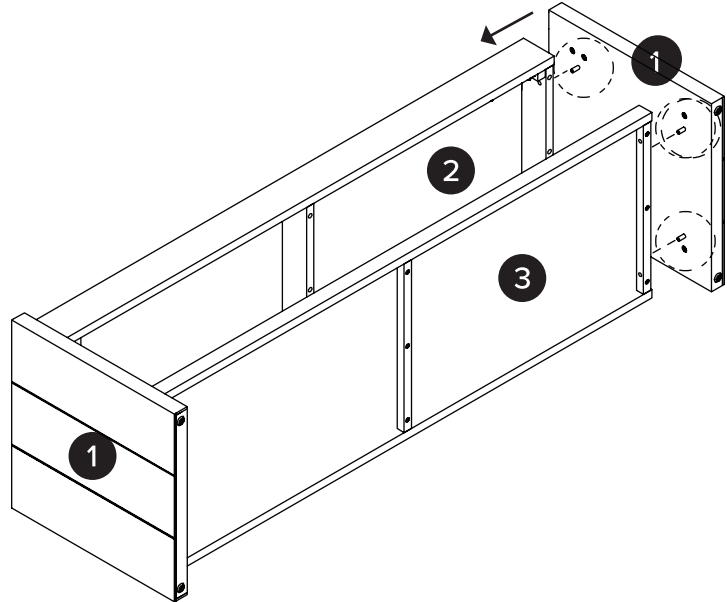
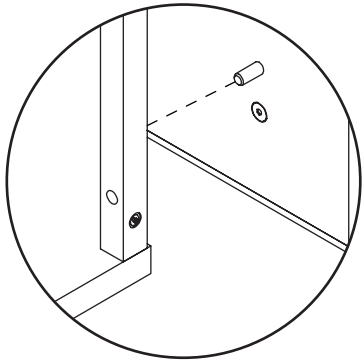

5

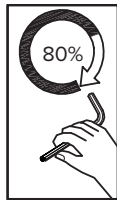
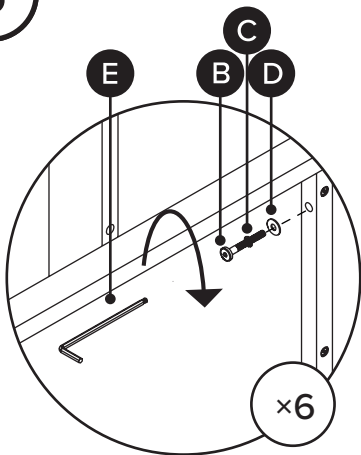

! Tighten bolts 80% only.

! Using ball head of allen key to wrench the bolt.

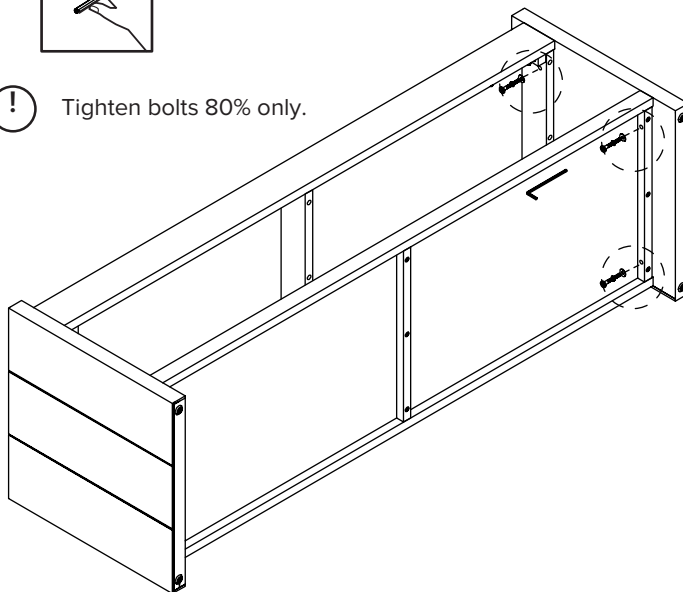

6



! Tighten 12 bolts 100% before turning it up

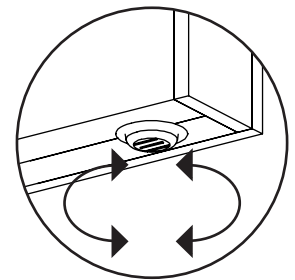
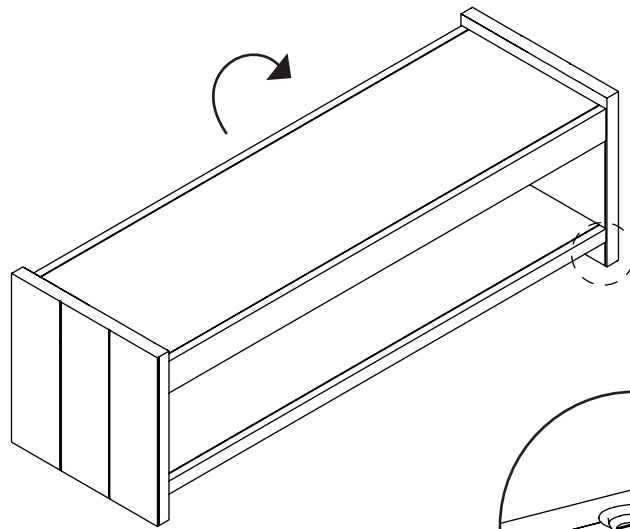

! Adjust levelers as needed.

7

