

# ARTICLE.

VERSION 1

## Assembly Instructions

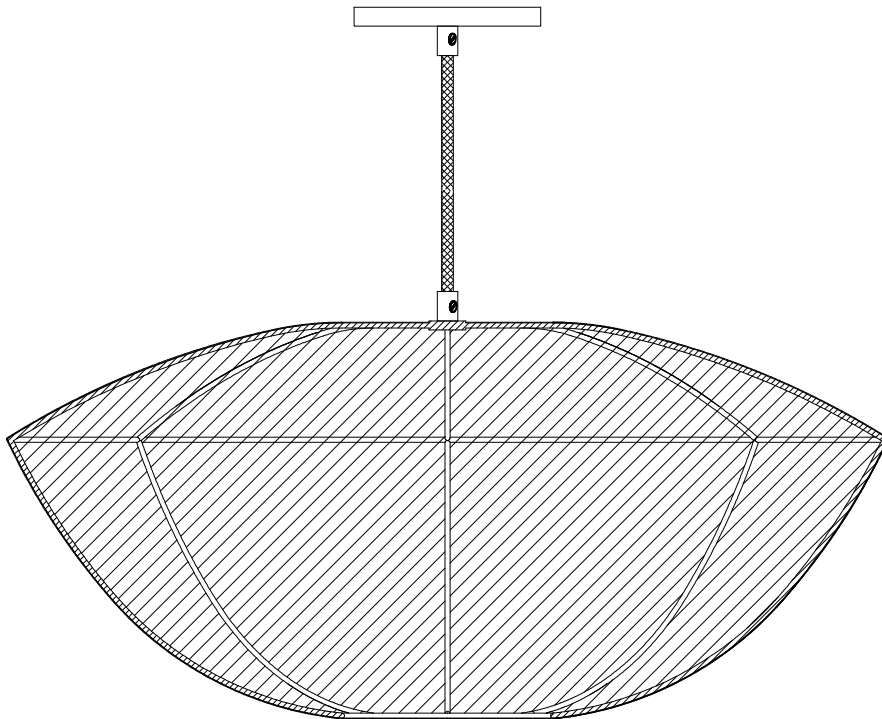

# KORI

Pendant Lamp

## ASSEMBLY INSTRUCTIONS

Read these instructions carefully and keep for future reference. Refer to parts inventory for guidance, and ensure you have all pieces before starting.

When assembling, place all parts on a soft, clean, and flat surface such as a carpet to prevent scratches.

If you're having difficulty, our friendly Customer Care team is always here to help. Call us at 1.888.746.3455 during business hours, email [service@article.com](mailto:service@article.com) or chat live at [article.com](http://article.com).

**!** Consultation with a professional electrician is recommended for the installation of this lamp.

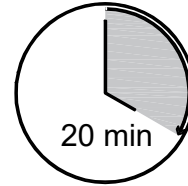

20 min

TIME

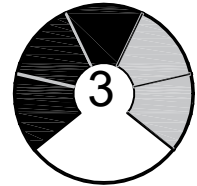



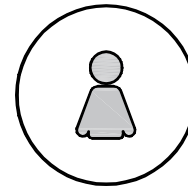

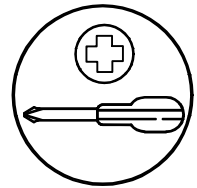

DIFFICULTY



# OF PEOPLE



REQUIRED TOOL

| PARTS INVENTORY |   |     |
|-----------------|---|-----|
| ID              | DESCRIPTION   | QTY |
| <b>A</b>        | MOUNTING BRACKET IRON ROUND (PRE-INSTALLED)  | 1   |
| <b>B</b>        | SHORT GREEN SCREW 8/32x8mm (PRE-INSTALLED)   | 1   |
| <b>C</b>        | MOUNTING SCREWS 8/32x25mm                    | 2   |
| <b>D</b>        | WIRE NUT                                     | 3   |
| <b>E</b>        | LAMP BODY                                    | 1   |
| <b>F</b>        | SIDE SCREWS 8/32x15mm (PRE-INSTALLED)        | 2   |
| <b>G</b>        | BULB 9W E26 A19                              | 1   |

1

! Detach 2 Screws(F) and mounting bracket iron round (A) to the lamp body (E)

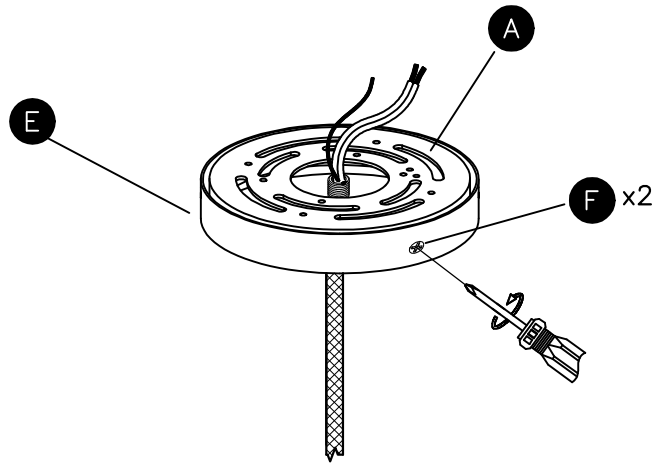

2

**CAUTION**  
Turn off power at main circuit pannel before starting installation.

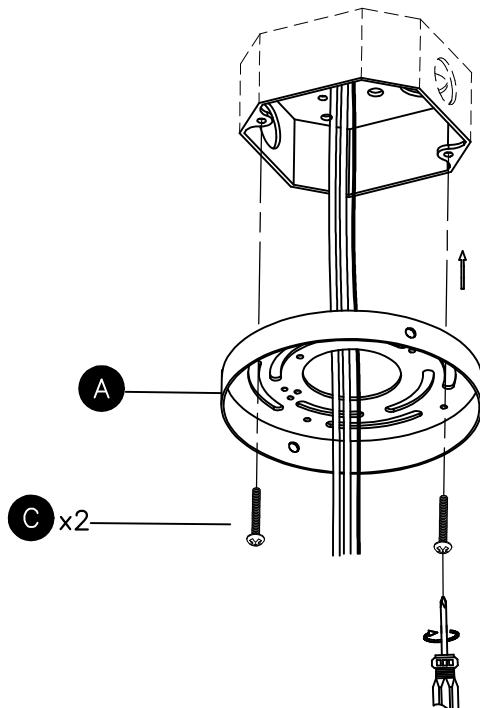

! Thread wires go through mounting bracket iron round (A) before attaching to junction box.

3

- ! Match up wires by color and attach with wire nuts (D).  
BLACK: Hot Fixture  
WHITE: Neutral Fixture  
GREEN OR BARE COPPER: Ground Wire

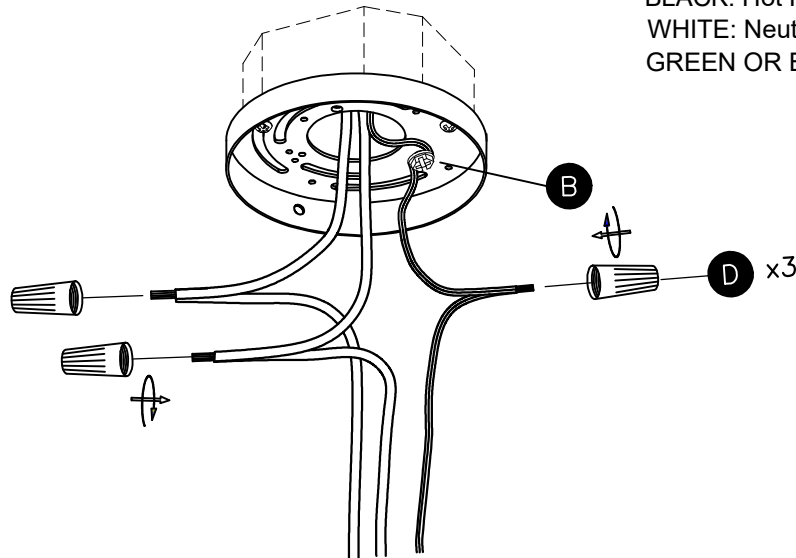

- ! If junction box does not have a green ground wire, attach ground wire from lamp to short green screw (B) on mounting bracket.

4

- ! Screw back side screw(F) to the lamp body(E) canopy to the mounting bracket iron round (A)

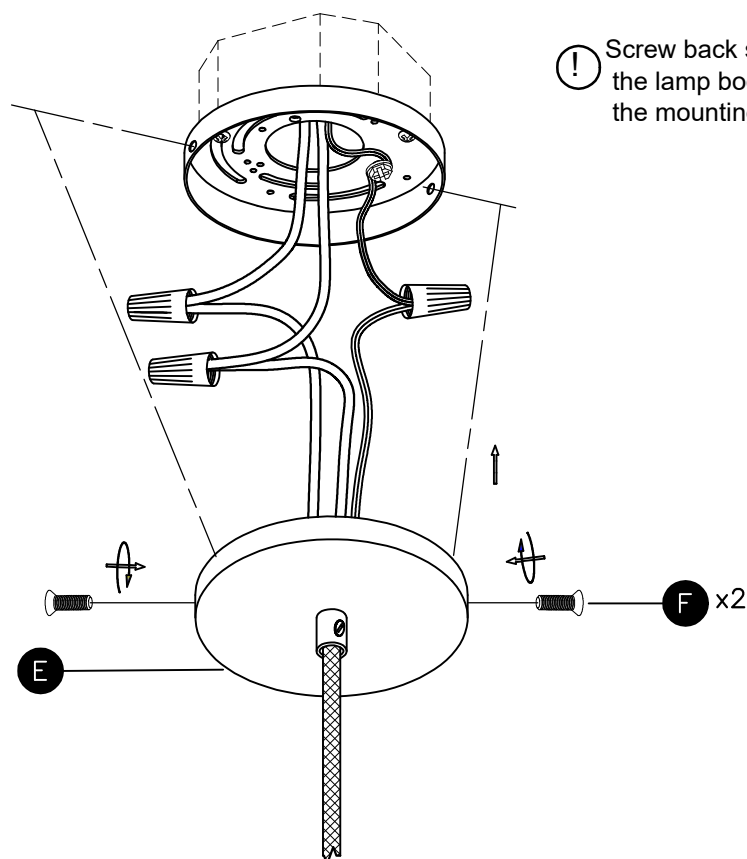

5

