

ARTICLE.

VERSION 1.0

Assembly Instructions

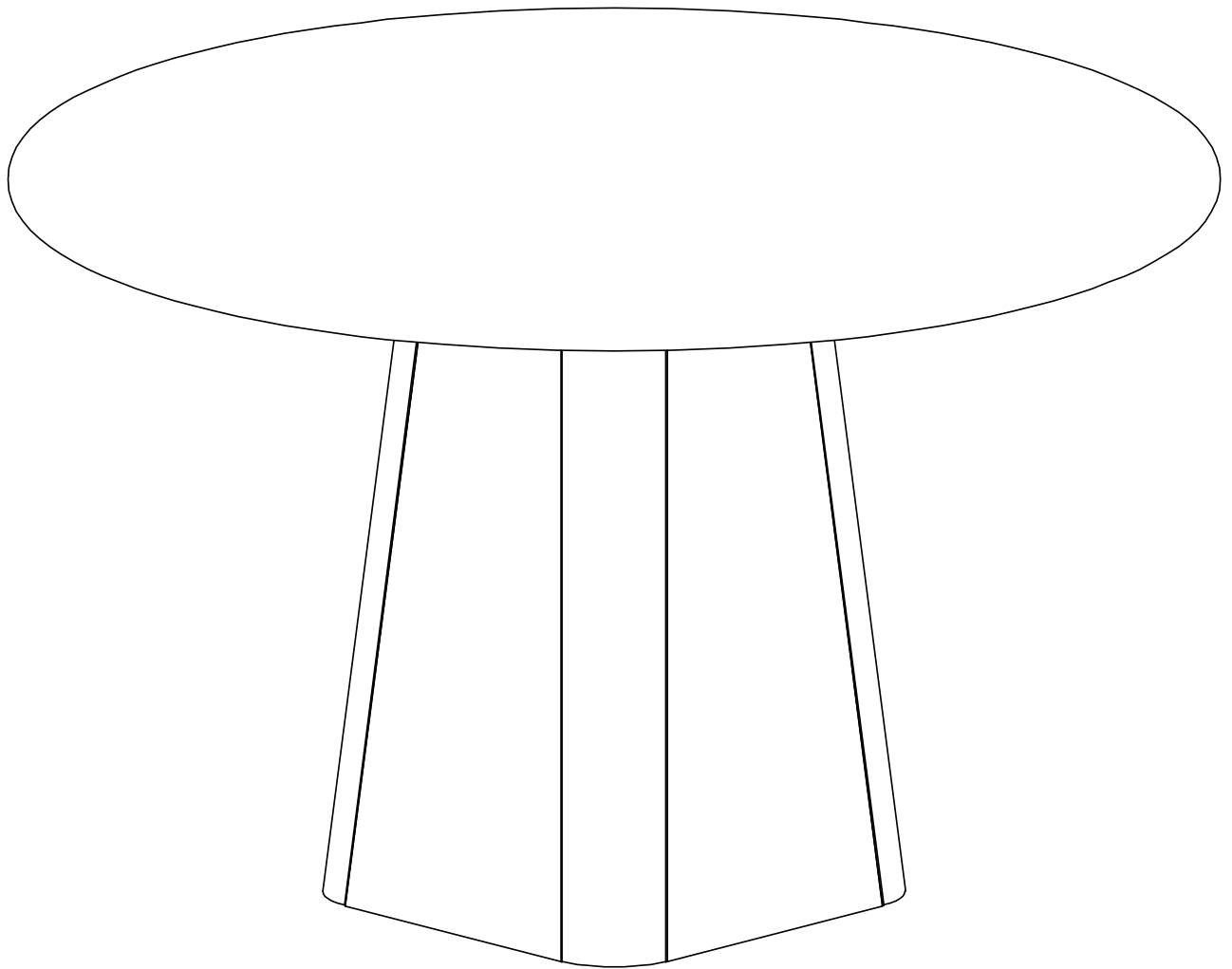

Torme

48" Round Dining Table

ASSEMBLY INSTRUCTIONS

Read these instructions carefully and keep for future reference. Refer to parts inventory for guidance, and ensure you have all pieces before starting.

When assembling, place all parts on a soft, clean, and flat surface such as a carpet to prevent scratches.

If you're having difficulty, our friendly Customer Care team is always here to help. Call us at **1.888.746.3455** during business hours, email service@article.com or chat live at [article.com](https://www.article.com)

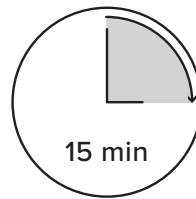

15 min

TIME

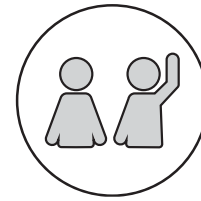



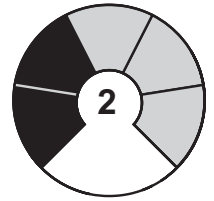

OF PEOPLE

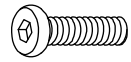

DIFFICULTY

PARTS INVENTORY		
ID	DESCRIPTION	QTY
1	TABLE TOP	1
2	TABLE BASE	1

HARDWARE LIST		
ID	DESCRIPTION	QTY
A	M8*25 MM BOLT 	8
B	LOCK WASHER 	8
C	WASHER 	8
D	ALLEN KEY 	1

1

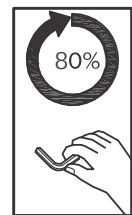
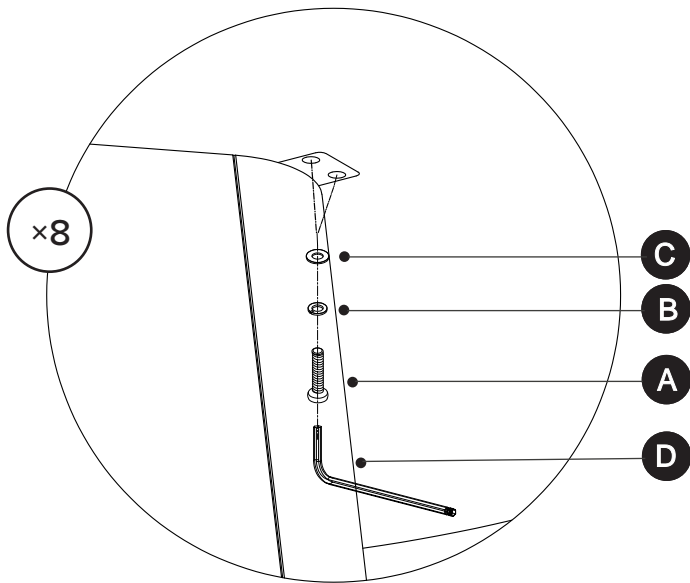

! Rotate the top until all the holes aligned before assembling the bolts.

! Tighten the bolts 80%.

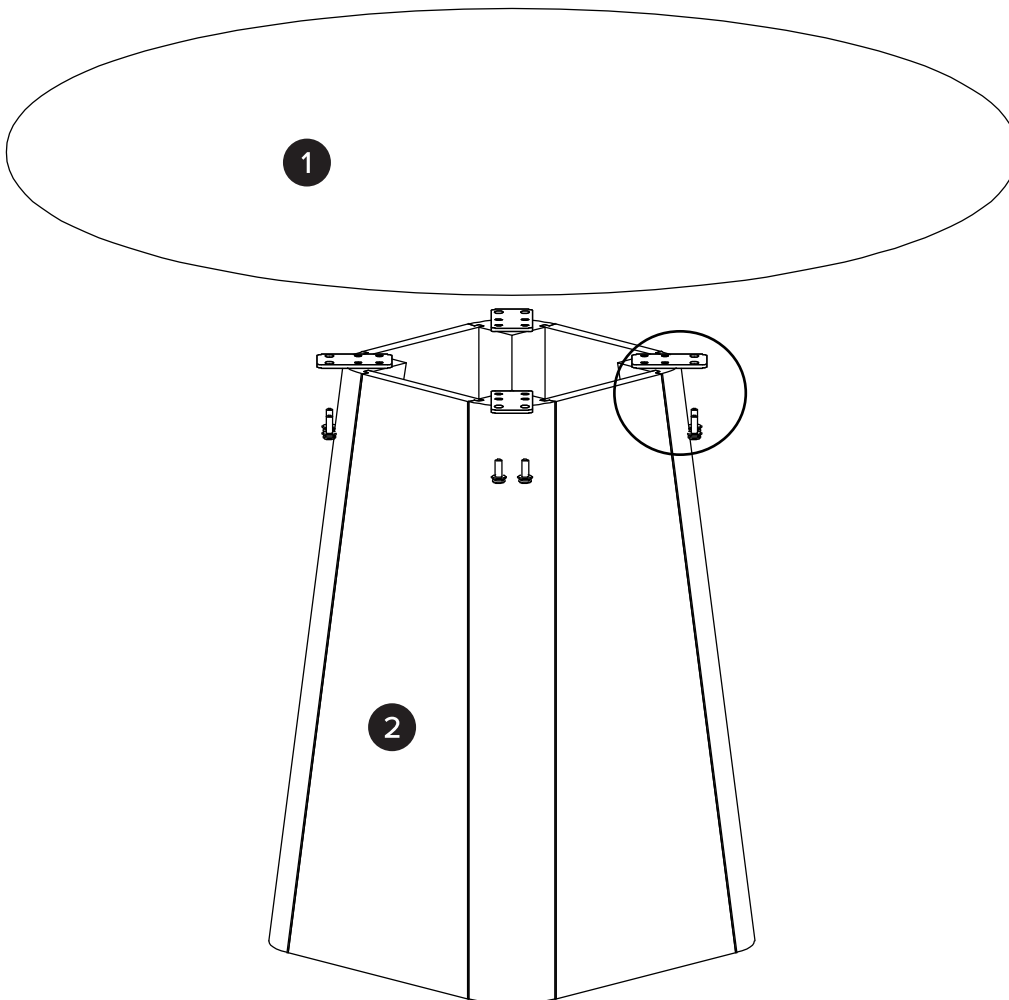

! Keep the base upright while assembling the tabletop due to the heavy base weight.

4

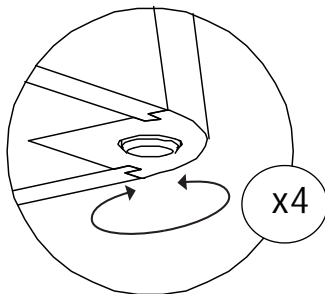
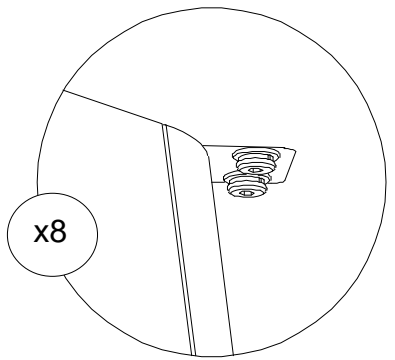
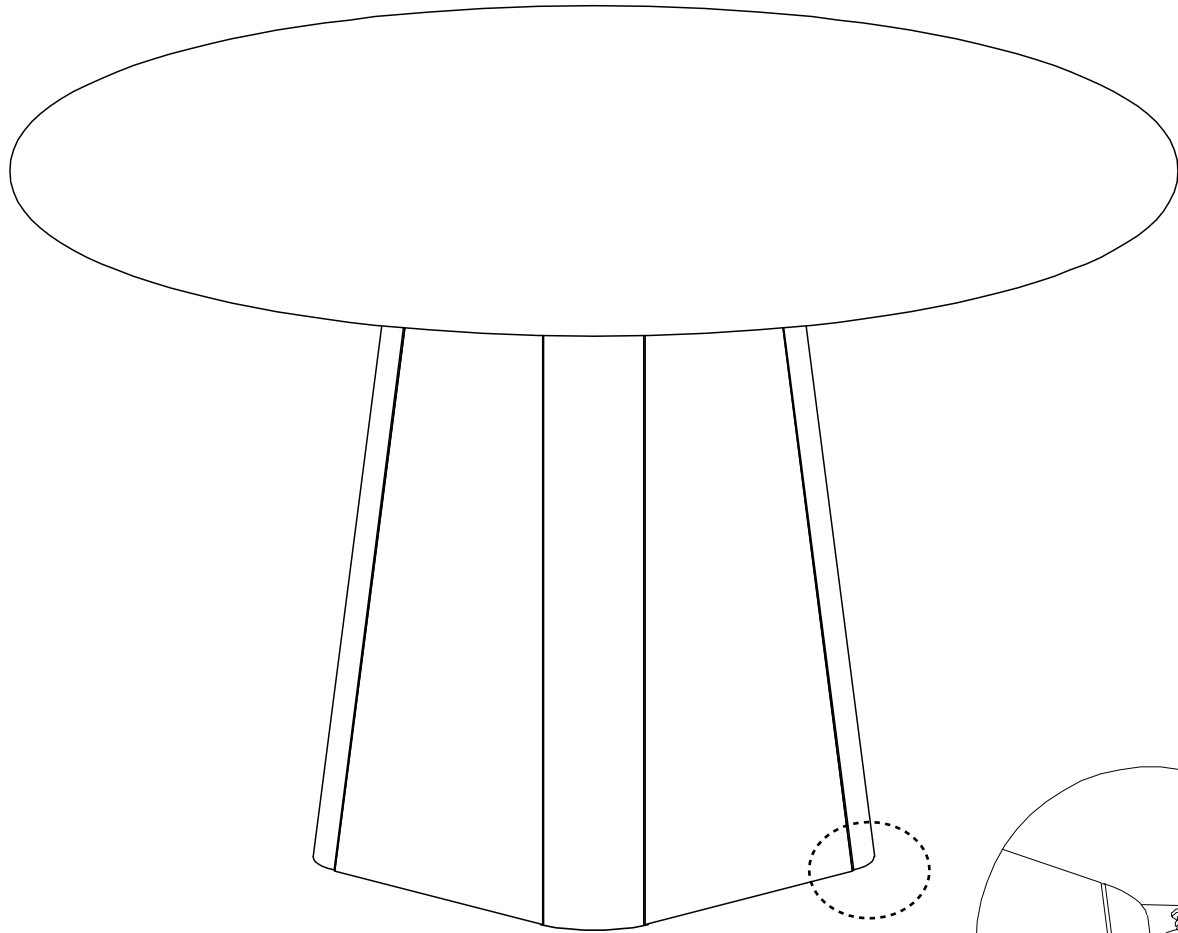

! Adjust levelers on legs as needed.



! Tighten all bolts 100%

IMPORTANT !

It is important that all bolts are re-tightened 2 weeks after assembly and once every 2 months in order to assure stability through-out the lifespan of this product.